



PANAGON
systems

HYDRAULIC PUMP MANUFACTURING

PVB PISTON PUMP MODELS **BUILT BY US**

PVB 5/6

PVB 45A

PVB 10/15

PVB 45

PVB 20/29

PVB 90



PARTS INFORMATION GUIDE

WWW.PANAGONSYSTEMS.COM



Founded nearly 35 years ago, Panagon Systems has remained a trusted company producing hydraulic parts on demand for a number of shops, manufacturers and industries. The company, located in Macomb, Michigan, is a hydraulic piston pumps and parts manufacturer, providing a vast variety of current and obsolete components. With a variety of CNC machines, Panagon produces finished product from raw materials. Which are then assembled, tested, painted and shipped from our facility. Panagon Systems attempts to fill the void OEM's create by manufacturing the phased out, expensive, unavailable pumps, motors and transmissions.

- Model 5/6** 2
- Parts Identification 3
- Parts Lists 4
- Identification of Model Code 6
- Model 10/15** 8
- Parts Identification 9
- Parts Lists 10
- Identification of Model Code 12
- Model 20/29** 14
- Parts Identification 15
- Parts Lists 16
- Identification of Model Code 18
- Model 45A** 20
- Parts Identification 21
- Parts Lists 22
- Identification of Model Code 24
- Model 45** 26
- Parts Identification 27
- Parts Lists 28
- Identification of Model Code 30
- Model 90** 32
- Parts Identification 33
- Parts Lists 34
- Identification of Model Code 36

Model PVB5/6

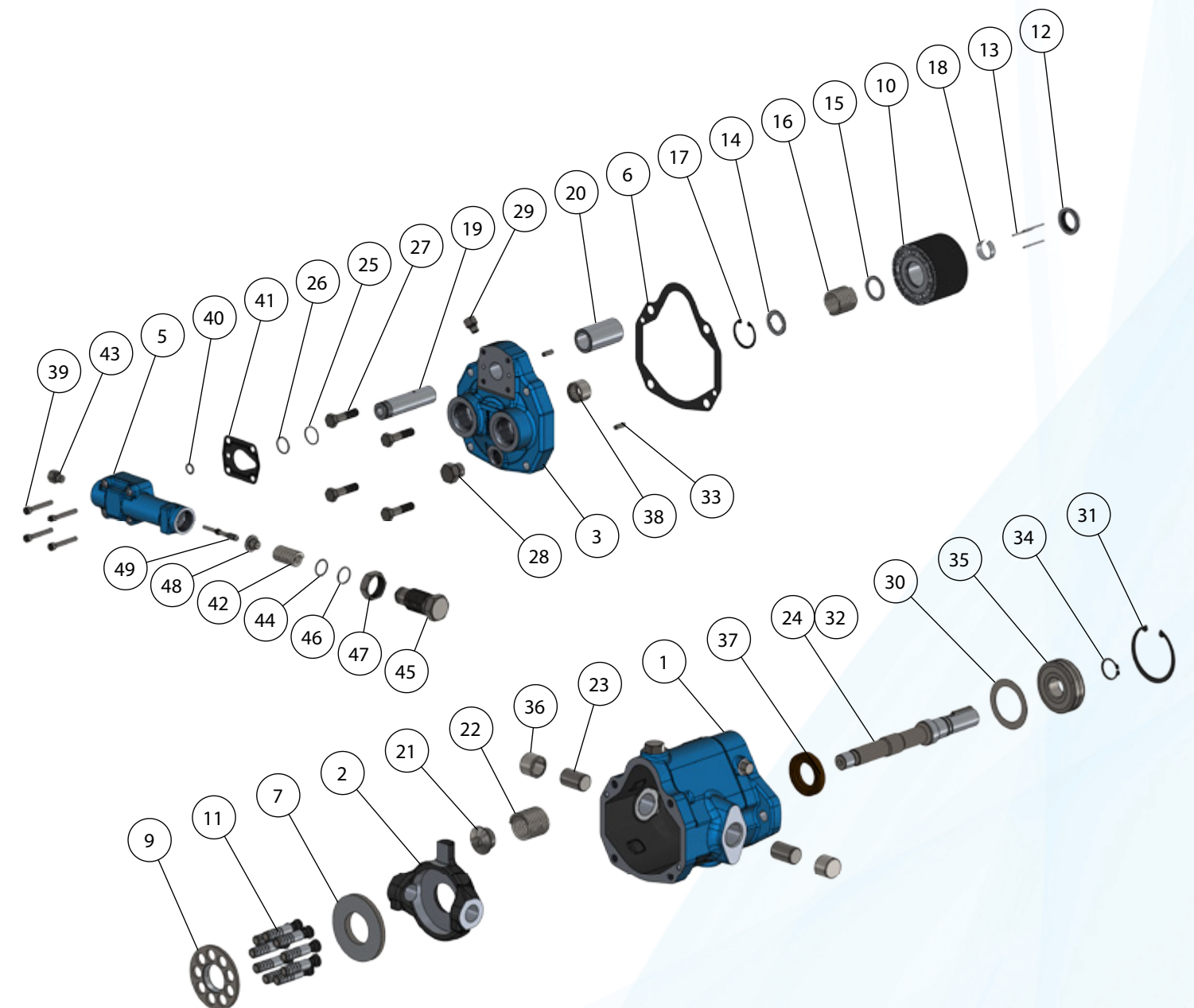
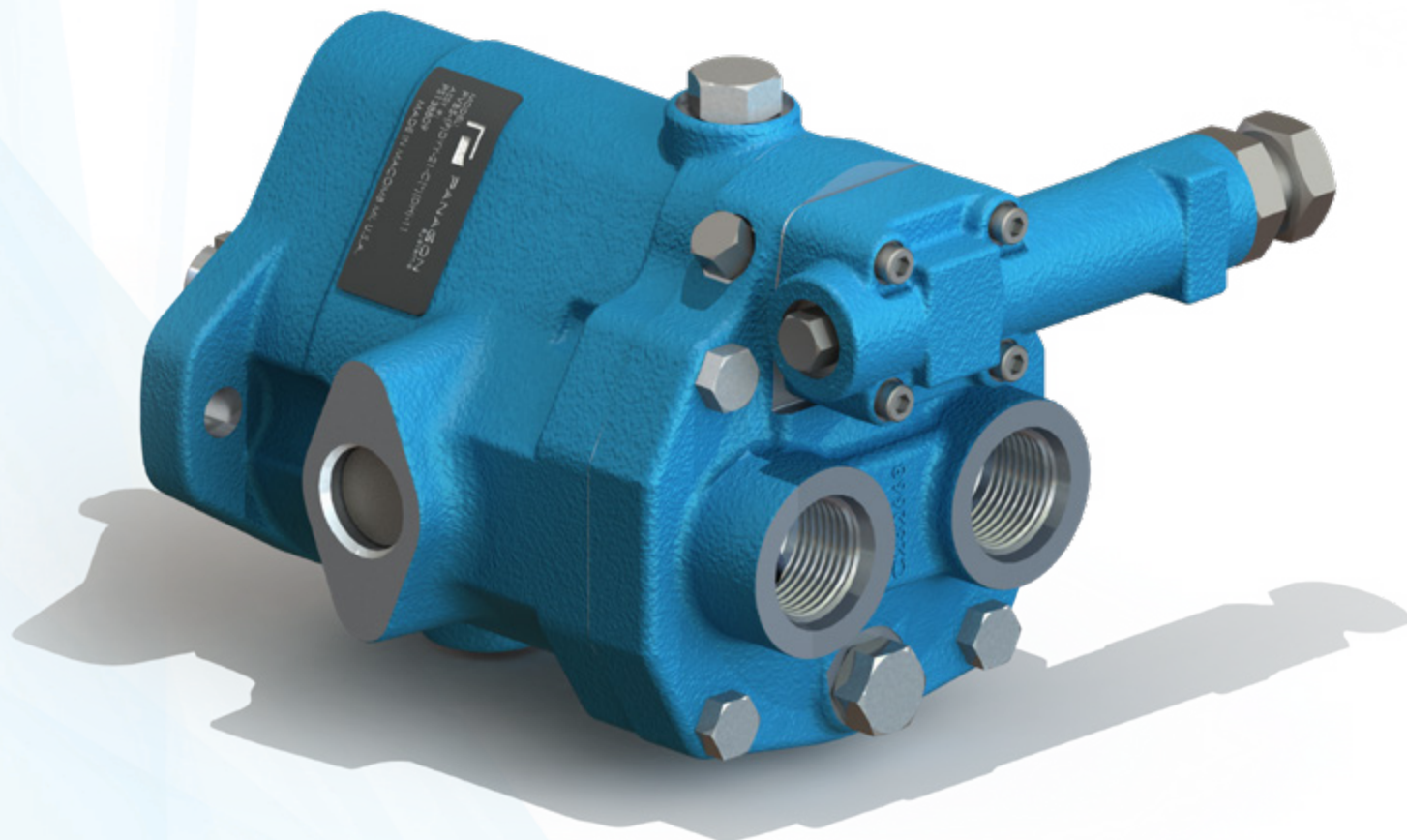

Model PVB5/6

ITEM	PART NUMBER		QTY	NOTE	DESCRIPTION
	Panagon	OEM			
1	See Table 4		1		Housing
2	See Table 4		1		Yoke
3	See Table 1		1	D	Valve Block
4	PS1459	164432	1	D	Instruction Plate
5	PS576862	932964	1	C/E	Compensator Body
6	PS1381	279615	1	A/B	Gasket
7	PS967	319245	1	F	Swashplate
8	See Table 4		1		Pin (H/M Only)
9	PS965	274249	1	F	Shoe Plate
10	See Table 2		1	F	Cylinder Block
11	See Table 2		9	F	Piston/Shoe S/A
12	PS1235	275485	1	F	Spherical Washer
13	PS1303	451936	3	F	Pin
14	PS968	273409	1	F	Lift Limiter
15	PS1302	451924	1	F	Thrust Washer
16	PS963	274787	1	F	Spring
17	PS969	165385-106	1	F	Retaining Ring
18	PS1539	451925	1	F	Pin Retainer
19	PS972	241924	1	C	Control Rod
20	PS971	241579	1	C	Control Piston
21	PS1496	373131	1	C	Seat
22	PS1495	373132	1	C	Inner Spring
23	See Table 3		2		Pintle
24	See Table 6		1		Drive Shaft
25	PS1617	185638 (RS-066)	1	C	Retaining Ring
26	PS5811361	104166-015 (173792)	1	A/B	"O"-Ring
27	PS1503	001253	4		Screw
28	PS5810893	115046-006 (181728)	2		"O"-Ring Plug
29	PS8123	115046-002 (398071)	2		"O"-Ring Plug
30	PS1490	190362	1		Seal Retainer
31	PS1373	140356-206	1		Retaining Ring
32	See Table 6		1		Key
33	PS7	95902-050 (167237)	2		Pin
34	PS1372	098653 (-078)	1		Retaining Ring
35	PS1230	283233	1		Bearing
36	See Table 3		2		Bearing
37	PS136800	237014	1	A/B	Shaft Seal
38	PS1238	039465	1	D	Bearing

ITEM	PART NUMBER		QTY	NOTE	DESCRIPTION
	Panagon	OEM			
39	PS1485	010358	4	E	Screw
40	PS134777	104166-011	1	E	"O"-Ring
41	PS90309	913451	1	A/E/J	Gasket
42	See Table 5		1	E	Spring
43	PS8123	115046-002	1	E	"O"-Ring Plug S/A
44	PS134800	104166-015	1	A/E	"O"-Ring
45	PS83428	392175	1	E/K	Adjusting Plug
46	PS577672	8770-015	1	E	Back-Up Ring
47	PS91024	937039	1	E	Jam Nut
48	PS36	234204	1	E	Seat
49	PS35	356986-L	1	E	Spool
50	PS135689	154018	1	B/G	"O"-Ring (TD)
51	PS1541	296101	1	G	Plug
52	PS1379	87885	1	H	Retaining Ring (TD)
53	PS1544	291956	1	H	Shaft Spacer (TD)
54	PS136829	292498	1	A/H	Shaft Seal (TD)

- A Included in PS989 / 919191 Seal Kit (F3 equivalent PS1014 / 919308)
- B Included in PS1005 / 919409 Seal Kit (F3 equivalent PS5818732 / 921159)
- C Used with Compensator Control Only
- D Included in Valve Plate S/A
- E Included in Pressure Compensator Kit
- F Included in Rotating Group
- G PVB**WY** Side port only
- H PVB**XY** Thru shaft only
- J Install gasket with small end of teardrop hole pointing in direction of compensator adj plug.
- K Model PVB 6 compensator pressure adjustment shall not exceed 2000 psi.

Model PVB5/6

Table 1 - Valve Block S/A		
Model Code	Panagon	OEM
PVB*-RS-21-C(*)-11	PS1036	942223
PVB*-LS-21-C(*)-11	PS1035	942224
PVB*-RD-21-H/M-10	PS1506	942225
MVB5-UD-20-H/M-10	PS1033	942227
PVB*-RSW/XY-21-C(*)-11	PS1032	942248
PVB*-LSW/XY-21-C(*)-11	PS1031	942249
PVB*-RDW/XY-21-H/M-10	PS1034	942226
PVB*-LDW/XY-21-H/M-10	PS1543	942247
PVQ 1***R-SE-10-C(*)	PS1036	02-142930
PVQ 1***R-SS-10-C(*)	PS93286	02-142932
PVQ 1***L-SE-10-C(*)	PS93285	02-142931
PVQ 1***L-SS-10-C(*)	PS93287	02-142933

Table 2 - Rotating Group						
Model Code	Panagon	OEM	Panagon	OEM	Panagon	OEM
Model	Cyl Block		Piston S/A		Rotating Group	
PVB 5 / PVQ 10	PS1538	677061	PS576442	942229	PS1178	875775
MVB 5		677059			PS1179	875772
PVB 6 / PVQ 13	PS1542	677060	PS576463	942230	PS970	875773

Table 3 - Pintle and Bearing						
Model Code	Panagon	OEM	Panagon	OEM	Panagon	OEM
Model	Pintle		Bearing		"O"-Ring	
All Pressure Compensated	PS1384	319243	PS1334	317572	-	-
M,H, No Control	PS1493	237191	PS1239	242222		(AB) 200088
	PS58187	273433				

Table 4 - Housing and Yoke										
Model Code	Panagon	OEM	Panagon	OEM	Panagon	OEM	Panagon	OEM		
Model	Yoke		Housing		Pin (H/M Only)		(D) Screw		(D) Rotation Plate	
M,H, No Control	PS1497	237192	PS1491	436462	PS8097	140508	PS1466	227407	PS1467	195060
All Pressure Compensated	PS1498	231557	PS1492	308334	N/A	N/A	PS1457	227401		404751

Table 5 - Pressure Compensator							
Model Code	Panagon	OEM	Panagon	OEM	Panagon	OEM	
Model	Comp. S/A		Spring		Load Sense Spring	Pressure Range (PSI)	
C	PS576864	942158	PS37	239371		250-3000 (PVB 5) (K) 250-2000 (PVB 6)	
CM	PS576865	942159		264693	-	250-1500	
CG	PS137530	942480	PS37	239371			
CMG	PS2205	941353		264693			
C**V(C)11B	PS137534	02-142729	PS37	239371	PS2210	581073	
C**V(C)11P	PS2207	02-142728					350, 250-450
C**V(C)24B	PS2208	02-142730			PS2211	581072	w/ bleed orifice (PVQ)
C**V(C)24P	PS2209	02-142727					
CD**	(Refer to service parts information I-3255-S)						

Table 6 - Shaft and Key				
Model Code	Panagon	OEM	Panagon	OEM
Model	Drive Shaft		Key	
PVB*	PS973	266162	PS1380	142843
PVQ*	PS1374	(G) 330329		
PVB*	PS761	(H) 291530		
	PS1895	286848	-	-
	PS1894	883030	PS84378	472255

Table 9				
Model Code	Panagon	OEM	Panagon	OEM
Model		(D) Rotation Plate		(D) Screw
All Pressure Compensated	PS-1467	404751	PS-1466	227407
H/M Only	PS-1467	195060	PS-1457	227401

Model PVB5/6

***VB * - (F) * * * Y - 21 * (*) (*) - 1 ***
 1 2 3 4 5 6 7 8 9 10 11 12 13

- 1 Variable Displacement In-line Piston Unit**
 P - Pump
 M - Motor
- 2 USgpm Flow Rating @1800 RPM**
 5 USgpm
 6 USgpm
- 3 Mounting F - Foot Bracket**
 (Omit for flange mount)
- 4 Rotation**
 R Clockwise (Right hand)
 L Counterclockwise (Left hand)
 U Either Direction (Motor Only)
- 5 Swash Plate Movement**
 D Both sides of center
 S One side of center
- 6 Optional Features**
 W Side Ports
 X Thru Shaft
 (Omit for non thru drive)
- 7 Shift End**
 Y Standard
- 8 Pump Design**

- 9 Control Type**
 Pressure Compensator
 C 250-3000 psi (PVB5)
 250-2000 psi (PVB6)
 CM 250-1500 psi (PVB5&6)
 CVP Pressure Limiter Load Sensing
 H Hand wheel
 M Lever
- 10 C - Adjustable Maximum Displacement Stop**
 (Pressure compensated models Only See I-3255-S)
- 11 Other Control Options**
 L Left hand viewing shaft end
 (Omit for right hand models)
- 12 Compensator Variation**
 D Dual-range (electric control 115 volts-60 cycle)
 DH Dual-range (hydraulic control)
 G Hydraulic remote (left hand only expect CCG models)
- 13 Control Design Number**
 11 Control Design
 20 Control Design

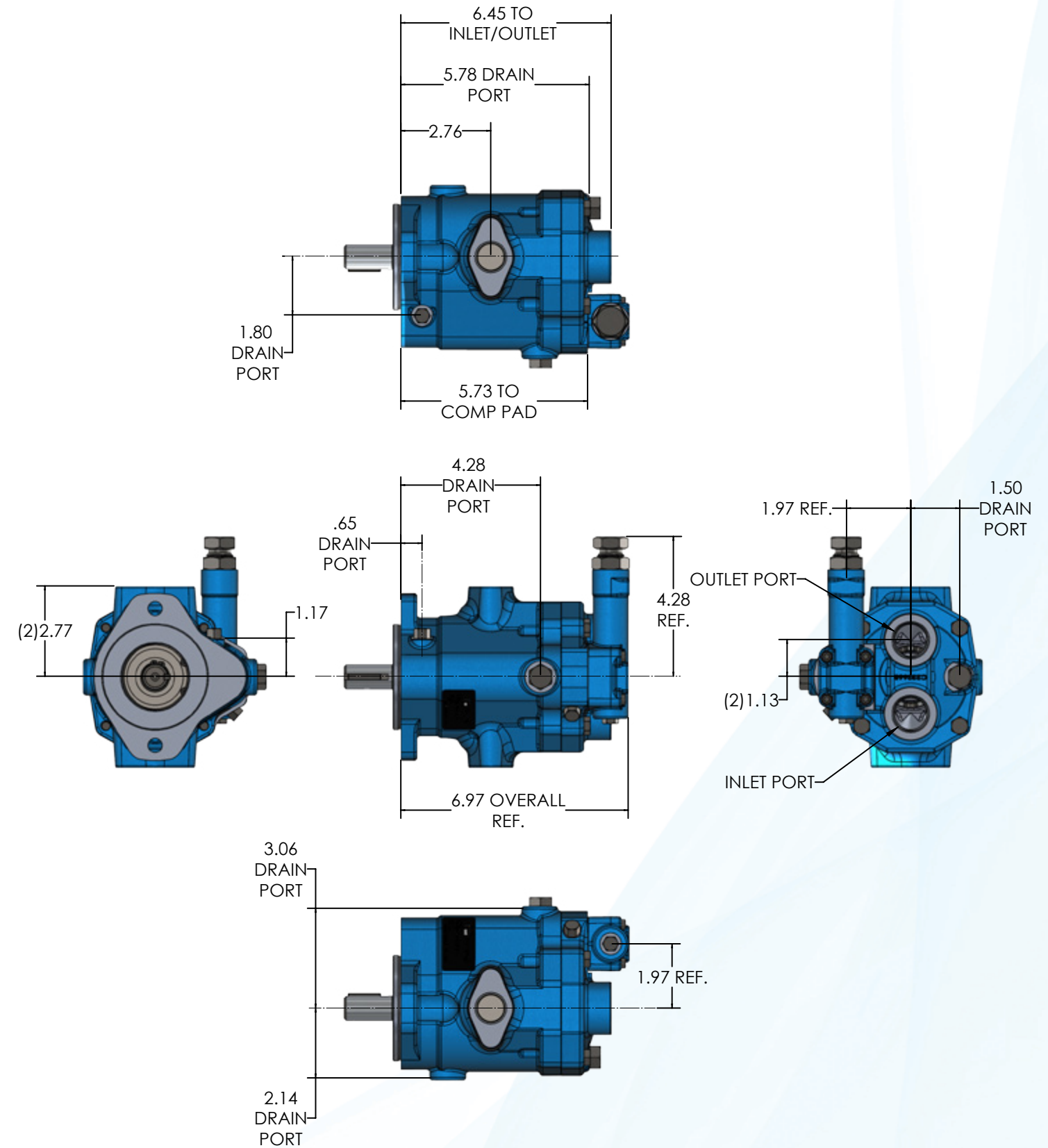

Model PVB10/15

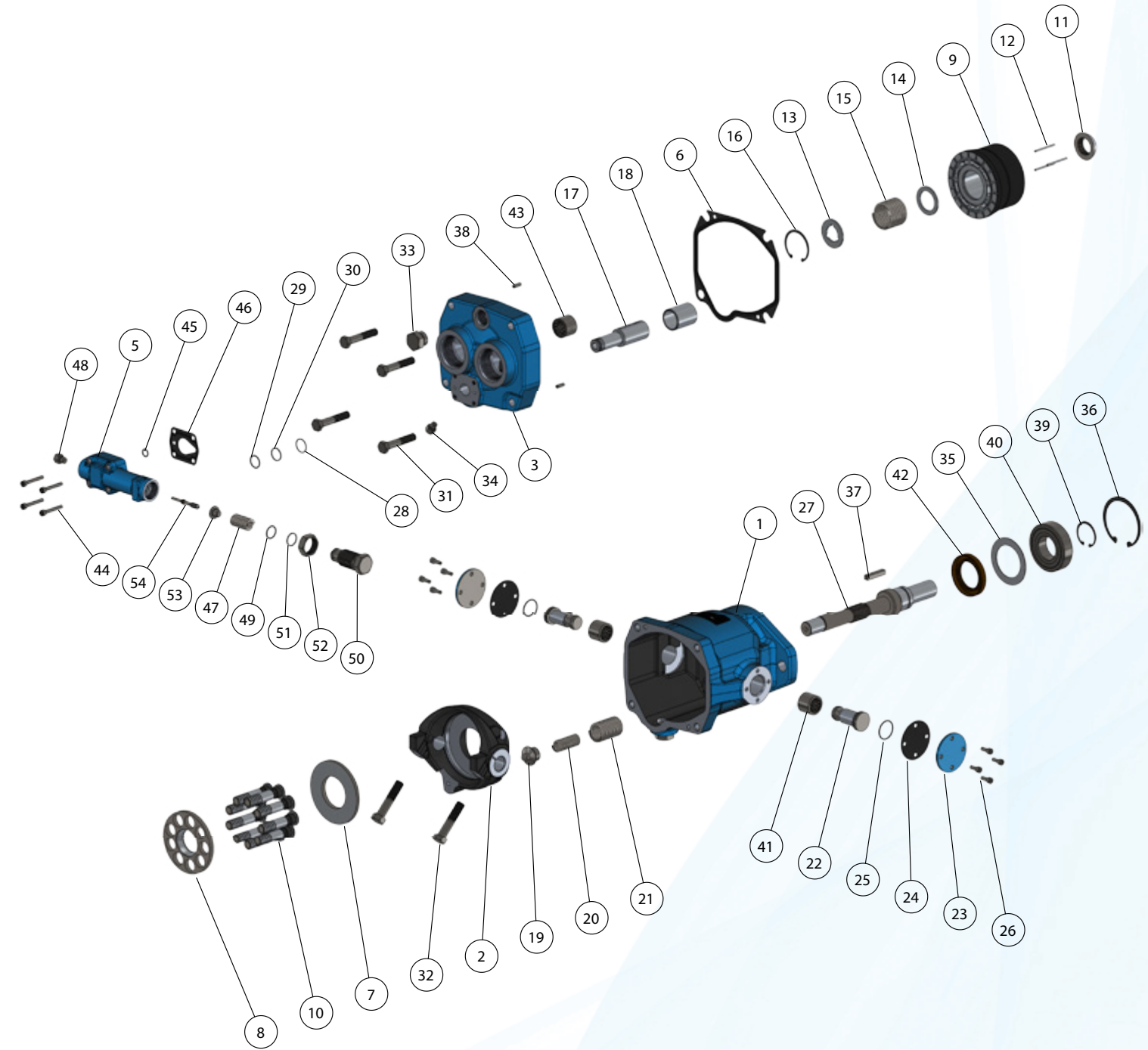
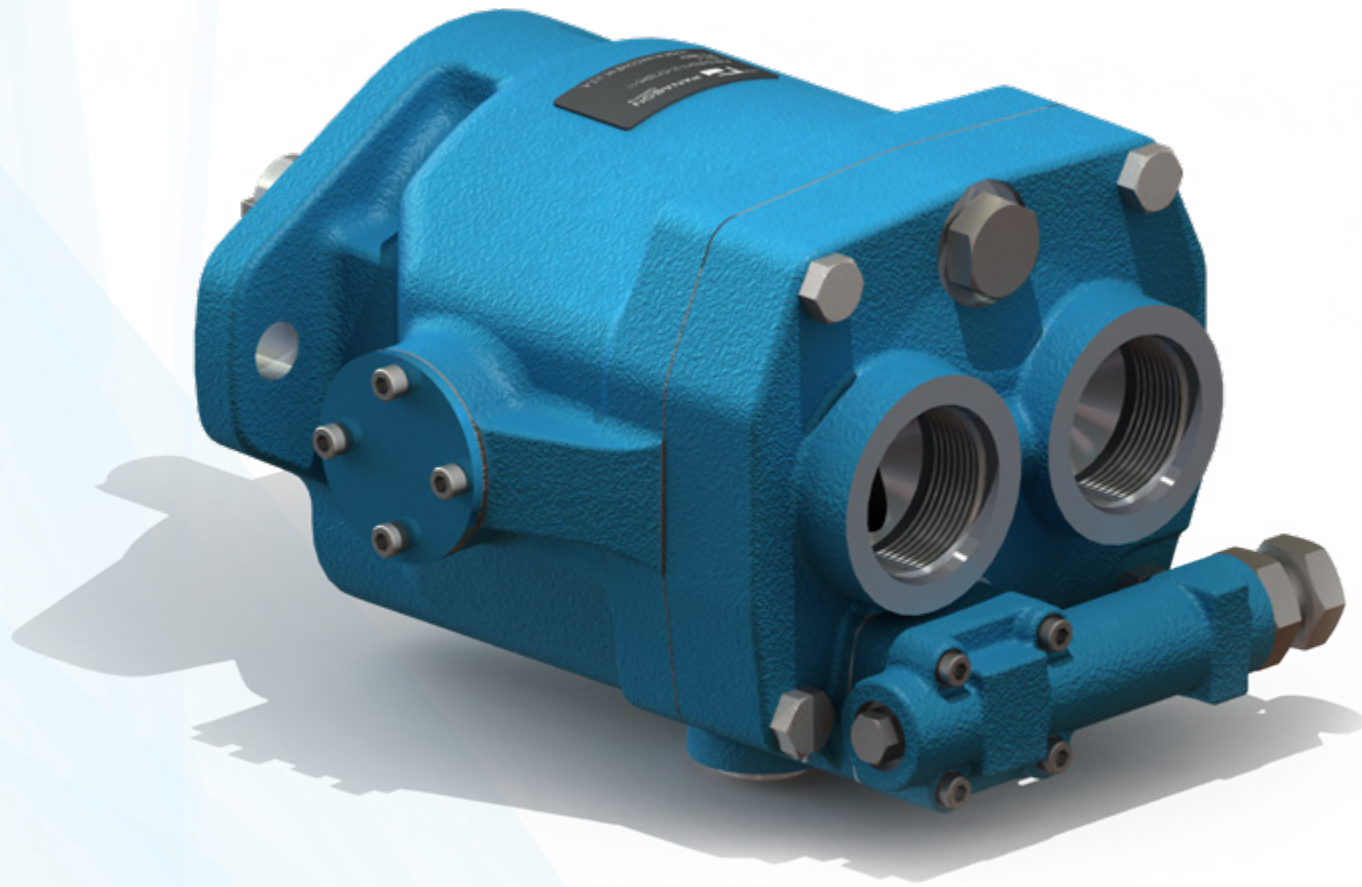

Model PVB10/15

ITEM	PART NUMBER		QTY	NOTE	DESCRIPTION
	Panagon	OEM			
1	See Table 4		1		Housing
2	See Table 4		1		Yoke
3	See Table 1		1	C	Valve Block
4	PS1459	164432	1	C	Instruction Plate
5	PS-576862	932964	1	B/D	Compensator
6	PS28	317162	1	A	Gasket
7	PS1000	239077	1	E	Swashplate
8	PS996	275961	1	E	Shoe Plate
9	See Table 2		1	E	Cylinder Block
10	See Table 2		9	E	Piston/Shoe S/A
11	PS167	423324	1	E	Spherical Washer
12	PS56	248812	3	E	Pin
13	PS58	245223	1	E	Lift Limiter
14	PS171	241954	1	E	Thrust Washer
15	See Table 2		1	E	Spring
16	PS-956	393509 (-150)	1	E	Retaining Ring
17	PS2429	387828	1	B	Control Rod
18	PS7401	386530	1	B	Control Piston
19	PS12	240535	1	B	Seat
20	PS10	317239	1	B	Inner Spring
21	PS11	278634	1	B	Outer Spring
22	See Table 3		2		Pintle
23	See Table 3		2		Pintle Cover
24	See Table 3		2		Pintle Gasket
25	PS134835	166360	2		"O"-Ring
26	PS-5800660	PS-5800660	8		Screw
27	See Table 6		1		Drive Shaft
28	PS1617	185638	1	C	Retaining Ring
29	PS134800	104166-015 (173792)	1	A	"O"-Ring
30	PS577672	8770-015 (186947)	1	A	Back-Up Ring
31	PS776	001276	4		Screw
32	PS958	001306	2		Screw
33	PS-5814121	115046-008	2		"O"-Ring Plug
34	PS8123	115046-002 (398071)	1		"O"-Ring Plug
35	PS16	274382	1		Seal Retainer
36	PS19	120428 (-244)	1		Retaining Ring
37	See Table 6		1		Key
38	PS7	95902-050 (167237)	2		Pin
39	PS18	119982 (-118)	1		Retaining Ring
40	PS1201	326805	1		Bearing
41	PS181	012016	2		Bearing
42	PS136797	343573	1	A	Shaft Seal
43	PS181	012016	1	C	Bearing

ITEM	PART NUMBER		QTY	NOTE	DESCRIPTION
	Panagon	OEM			
44	PS1485	010358	4	D	Screw
45	PS5813533	104166-011	1	D	"O"-Ring
46	PS90309	913451	1	A/D/H	Gasket
47	See Table 5		1	D	Spring
48	PS8123	115046-002	1	D	"O"-Ring Plug
49	PS5811361	104166-015	1	A/D	"O"-Ring
50	PS83428	392175	1	D/K	Adjusting Plug
51	PS5811360	8770-015	1	D	Back-Up Ring
52	PS91024	937039	1	D	Jam Nut
53	PS36	234204	1	D	Seat
54	PS35	356986-L	1	D	Spool
55	PS1569	294669	1	C/G	Bearing (TD)
56	PS1439	374704		C/G	Snap Ring (TD)
57	PS1567	329465	1	C/F	Plug
58	PS1438	99578	1	C/G	Retaining Ring (TD)
59	PS136794	294958	1	A/C/G	Shaft Seal (TD)

- A Included in PS1006 / 919729 Seal Kit (F3 equivalent PS1016 / 920186)
- B Used with Compensator Control Only
- C Included in Valve Plate S/A
- D Included in Pressure Compensator Kit
- E Included in Rotating Group
- F PVB**WY** Side port only
- G PVB**XY** Thru shaft only
- H Install gasket with small end of teardrop hole pointing in direction of compensator adj plug.
- J Model PVB 15 compensator pressure adjustment shall not exceed 2000 psi.

Model PVB10/15

Table 1 - Valve Block S/A		
Model Code	Panagon	OEM
PVB10-RD(Y)-3*-H/M-10	PS1475	942160
PVB10-LD(Y)-3*-H/M-10	PS1474	942161
MVB10-UD(Y)-3*-H/M-10	PS1473	942162
PVB15-RD(Y)-3*-H/M-10	PS1472	942163
PVB15-LD(Y)-3*-H/M-10	PS1471	942164
PVB10-RS(Y)-3*-C(*)-11	PS20	942165
PVB10-LS(Y)-3*-C(*)-11	PS24	942166
F6-PVB15-RS(Y)-3*-C(*)-11	PS175	942167
F6-PVB15-LS(Y)-3*-C(*)-11	PS179	942168
PVQ20**-R-SE-10-C(*)	PS93288	02-142934
PVQ20**-R-SS-10-C(*)	PS2213	02-142936
PVQ20**-L-SE-10-C(*)	PS93289	02-142935
PVQ20**-L-SS-10-C(*)	PS93291	02-142937
PVQ20**-R-A(*)-10-C(*)	PS93301	02-143198
PVQ20**-L-A(*)-10-C(*)	PS93302	02-143199
PVQ32**-R-SE-10-C(*)	PS93292	02-142938
PVQ32**-R-SS-10-C(*)	PS93294	02-142940
PVQ32**-L-SE-10-C(*)	PS93293	02-142939
PVQ32**-L-SS-10-C(*)	PS93295	02-142941
PVQ32**-R-A(*)-10-C(*)	PS93303	02-143200
PVQ32**-L-A(*)-10-C(*)	PS93304	02-143201

Table 2 - Rotating Group								
Model Code	Panagon	OEM	Panagon	OEM	Panagon	OEM	Panagon	OEM
Model	Cyl Block		Piston S/A		Rotating Group		Spring	
PVB 10 / PVQ 20	PS48	321703	PS1003	942047	PS1	938276	PS169	247294
MVB 10								
PVB 15 / PVQ 32	PS160	260860	PS164	941887	PS157	938273	PS1468	403858
F6-PVB 15								

Table 3 - Pintle and Bearing								
Model Code	Panagon	OEM	Panagon	OEM	Panagon	OEM	Panagon	OEM
Model	Control Pintle		Other Pintle		Gasket		Cover	
Pressure Compensated / PVQ	PS4	265425	PS4	265425	(2)	(2) 932958	PS90795	932957
H-10					PS1469	269657	(1)	(1) 932958
M-10	PS1470	269658						

Table 4 - Housing and Yoke								
Model Code	Panagon	OEM	Panagon	OEM	Panagon	OEM	Panagon	OEM
Model	Yoke		Housing		(C) Screw		(C) Rotation Plate	
M,H, No Control	PS1463	325689	PS1464	308327	PS1457	227401	PS1467	195060
Pressure Compensated / PVQ					PS190	342743	PS90797	357652
			PS1465	398719				

Table 5 - Pressure Compensator						
Model Code	Panagon	OEM	Panagon	OEM	Panagon	OEM
Model	Comp. S/A		Spring		Load Sense Spring	
C	PS576864	942158	PS37	239371		
CM	PS576865	942159		264693		
CG	PS137530	942480	PS37	239371		
CMG	PS2205	941353		264693		
C**V(C)11B	PS137534	02-142729	PS37	239371	PS2210	581073
C**V(C)11P	PS2207	02-142728				
C**V(C)24B	PS2208	02-142730			PS2211	581072
C**V(C)24P	PS2209	02-142727				
CD**						

(Refer to service parts information I-3255-S)

Table 6 - Shaft and Key										
Model Code	Panagon	OEM	Panagon	OEM	Panagon	OEM	Panagon	OEM	Panagon	OEM
Model	Drive Shaft		Key		Coupling		Snap Ring		"O"-Ring	
VB-*-3*	PS820	261478	PS1455	022971						
VB-*-3*	PS13	270369	PS1456	058303						
PVB1*	PS819	292077	N/A	N/A						
PVQ**	PS3630	883219	PS84379	472270						
PVQ**	PS3631	875620								
PVQ**A9	PS3632	883302	PS1456	058303	PS10103	426770	PS10101	223172	PS134989	351776
PVQ**A11	PS3633	860501			PS86394	577937	PS1437	092757		

Table 9				
Model Code	Panagon	OEM	Panagon	OEM
Model		(D) Rotation Plate		(D) Screw
All Pressure Compensated	PS1467	404751	PS1466	227407
H/M Only	PS1467	195060	PS1457	227401

Model PVB10/15

(F3) - * VB * - (*) ** (*) Y - ** - * (*) (L) - **

1 2 3 4 5 6 7 8 9 10 11 12 13 14

- 1 Special Seals**
F3 Multi-fluid capability - Viton seals
F6 Soluble oil fluids
- 2 Model**
M - Motor
P - Pump
- 3 Model Type**
Variable displacement pump,
inline piston design
- 4 Flow Rating @1800**
10 USgpm
15 USgpm
- 5 Mounting**
F Foot Bracket
(Omit for flange mount)
- 6 Rotation**
Viewing from shaft end
R Right hand (CW)
L Left hand (CCW)
U Either direction (Motors only)
- 7 Swash Plate Movement**
S One side of center
D Both sides of center
- 8 Optional Features**
Flange Connected
(Omit for Oring Port)
- 9 Shaft**
Y Long shaft (standard)
(Omit for Short Shaft)

- 10 Pump Design Number**
30 Design Number
31 Design Number 30
40 Design Number
41 Design Number
- 11 Control Type**
C 250-3000 psi (10 USgpm)
250-2000 psi (15 USgpm)
CM Pressure compensated
CVP Pressure limiter load sensing
H Hand wheel
M Lever
- 12 Compensator Variation Options**
C Adjustable maximum stop
D Dual range
(Electric control - 115 volts - 60 cycles)
DH Dual range
(Hydraulic control)
E Start-up valve
- 13 Control Options**
L Left hand location viewing
shaft end (Omit for right hand location)
- 14 Control Design Number**
11 Control Design
12 Control Design
20 Control Design
30 Control Design

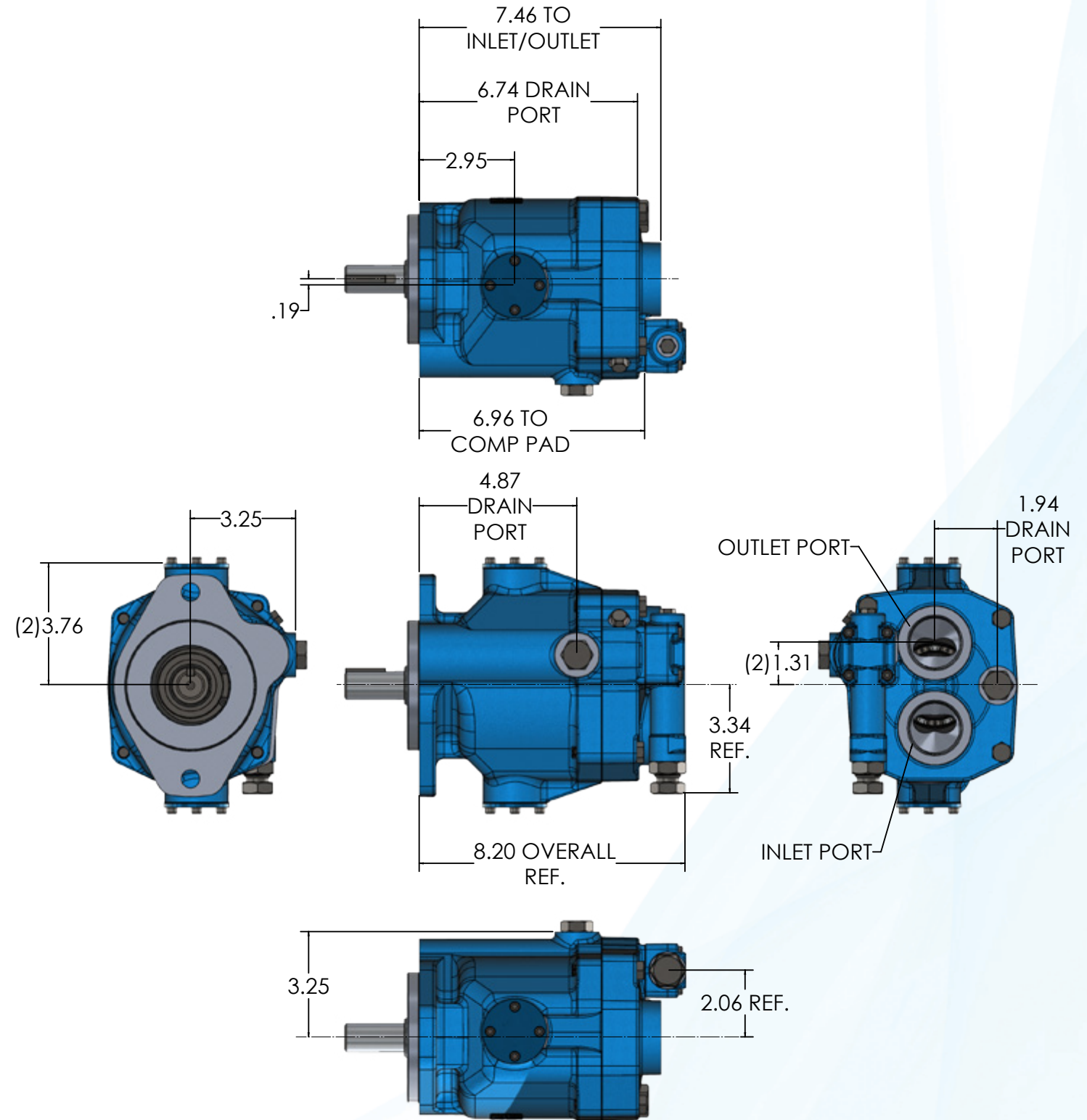

Model PVB20/29

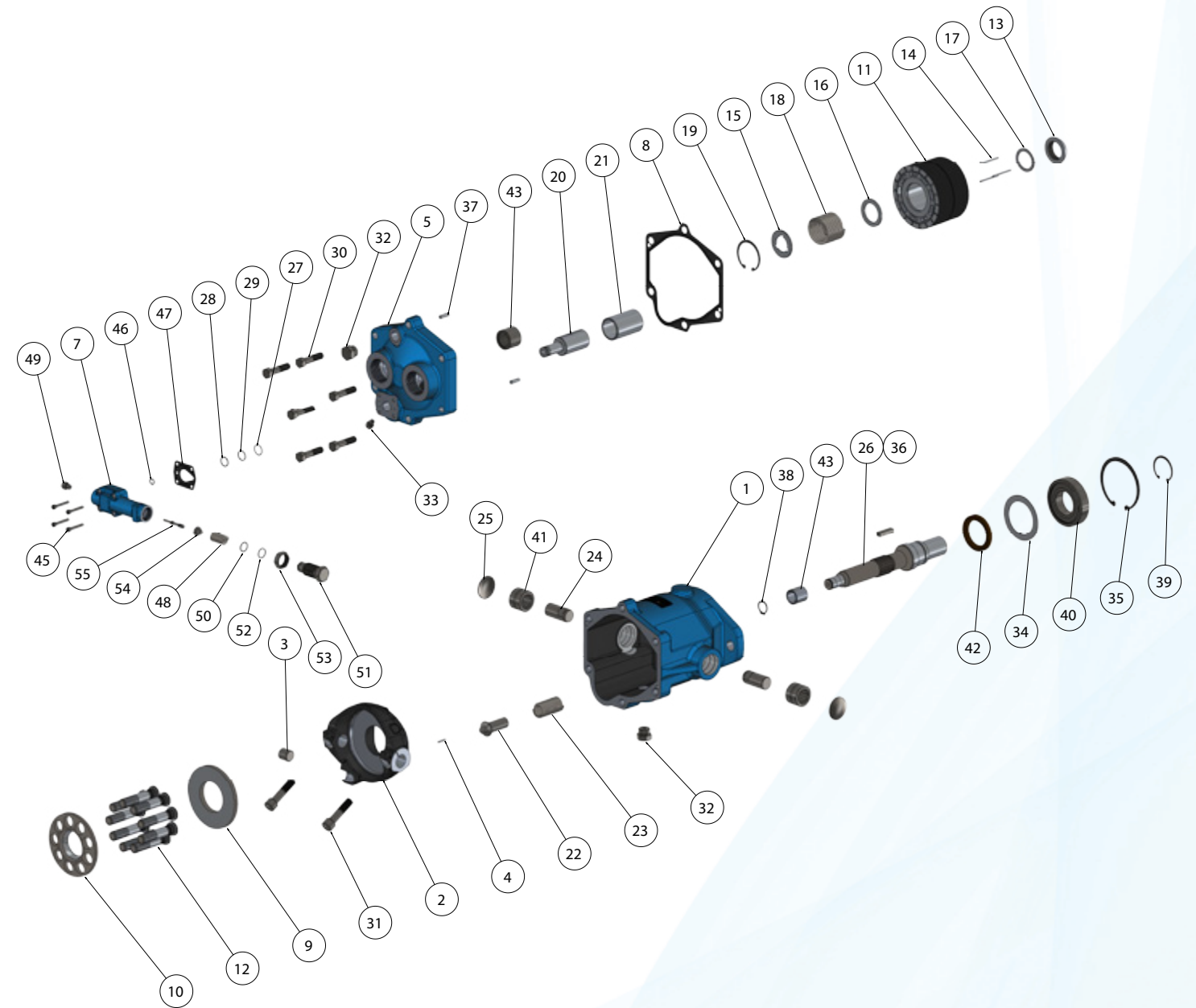
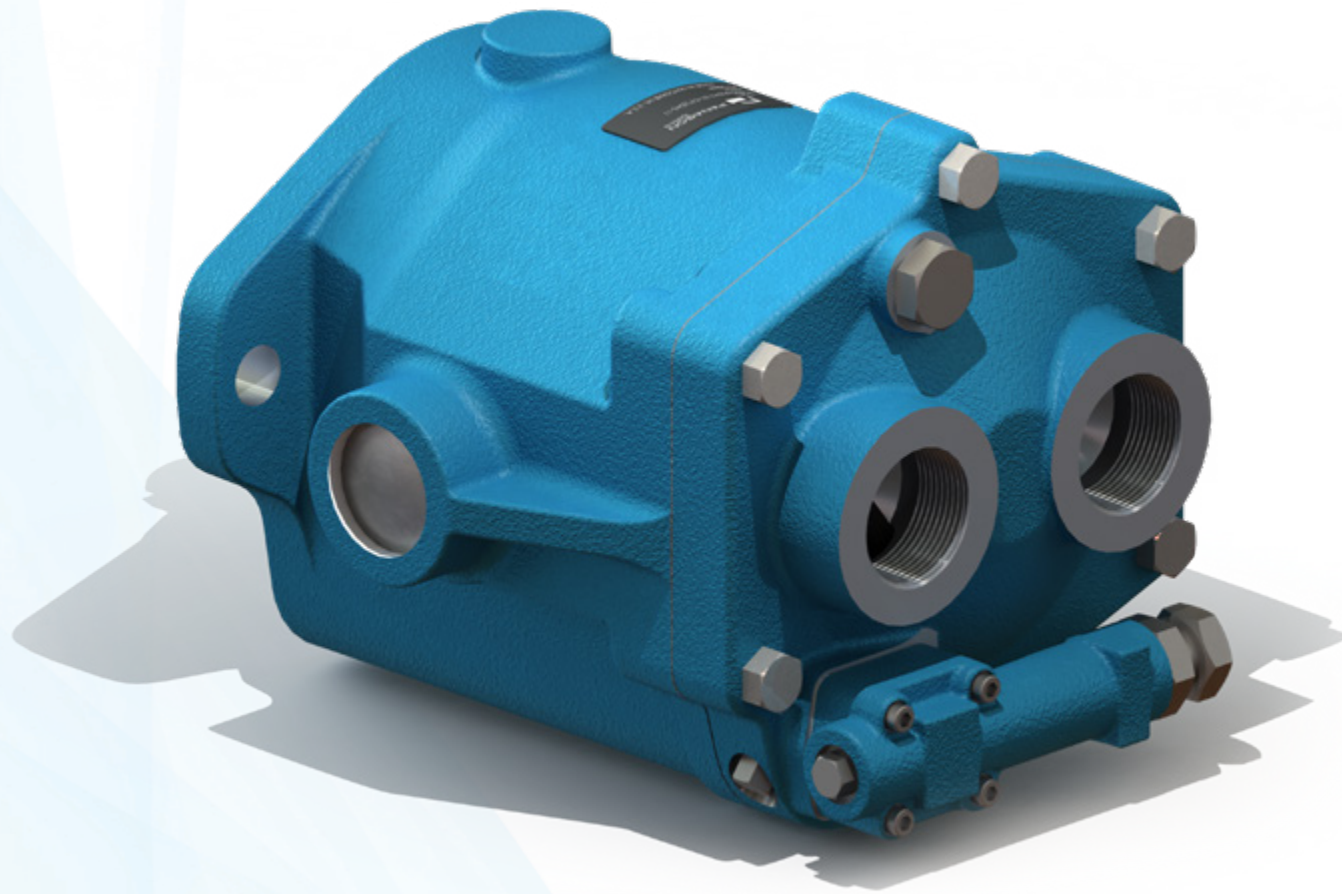

Model PVB20/29

ITEM	PART NUMBER		QTY	NOTE	DESCRIPTION
	Panagon	OEM			
1	See Table 4		1		Housing
2	See Table 4		1		Yoke
3	See Table 4		1		Roller
4	See Table 4		1		Roller Pin
5	See Table 1		1	C	Valve Block
6	PS1459	164432	1	C	Instruction Plate
7	PS576862	932964	1	B/D	Compensator
8	PS193	245976	1	A	Gasket
9	PS999	239335	1	E	Swashplate
10	PS995	248609	1	E	Shoe Plate
11	See Table 2		1	E	Cylinder Block
12	See Table 2		9	E	Piston/Shoe S/A
13	PS1591	283993	1	E	Spherical Washer
14	PS143	248836	3	E	Pin
15	PS147	244931	1	E	Lift Limiter
16	PS146	238780	1	E	Thrust Washer
17	PS1218	238836	1	E	Back-Up Washer
18	PS1297	246386	1	E	Spring
19	PS783	194025 (T)	1	E	Retaining Ring
20	PS112	379792	1	B	Control Rod
21	PS113	379793	1	B	Control Piston
22	PS93	245975	1	B	Seat
23	PS92	294079	1	B	Inner Spring
24	See Table 3		2		Pintle
25	See Table 3		2		Pintle Cover
26	See Table 6		1		Drive Shaft
27	PS1617	185638 (RS-066)	1	C	Retaining Ring
28	PS5811361	104166-015 (173790)	1	A	O-Ring
29	PS5811360	8770-015 (186947)	1		Back-Up Ring
30	PS109	001295	6		Screw
31	PS702	001116	2		Screw
32	PS5814121	115046-008	2		O-Ring Plug
33	PS8123	115046-002 (398071)	1		O-Ring Plug
34	PS716	194878	1		Seal Retainer
35	PS100	117506 (-312)	1		Retaining Ring
36	See Table 6		1		Key
37	PS780	003913	2		Pin
38	PS1241	193734	1		Retaining Ring
39	PS99	117507	1		Retaining Ring
40	PS98	283090 (6208ZZ)	1		Bearing
41	See Table 3		2		Bearing
42	PS136821	295262	1	A	Shaft Seal
43	PS106	251108 (BHA1616)	1	C	Bearing
44		292499	1		Shaft Spacer

ITEM	PART NUMBER		QTY	NOTE	DESCRIPTION
	Panagon	OEM			
45	PS1485	010358	4	E	Screw
46	PS134777	104166-011	1	E	"O"-Ring
47	PS90309	913451	1	A/E/J	Gasket
48	See Table 5		1	E	Spring
49	PS8123	115046-002	1	E	"O"-Ring Plug S/A
50	PS134800	104166-015	1	A/E	"O"-Ring
51	PS83428	392175	1	E/K	Adjusting Plug
52	PS577672	8770-015	1	E	Back-Up Ring
53	PS91024	937039	1	E	Jam Nut
54	PS36	234204	1	E	Seat
55	PS35	356986-L	1	E	Spool
56	PS1169	400170	1	F	Plug (TD)
57	PS1435	307041	1	G	Retaining Ring (TD)
58	PS136787	590026	1	A/G	Shaft Seal (TD)

- A Included in PS985 / 919683 Seal Kit (F3 equivalent PS986 / 919847)
- B Used with compensator control only
- C Included in Valve Plate S/A
- D Included in Pressure Compensator Kit
- E Included in Rotating Group
- F PVB2*(F)*SFX-20-C(M)-11 Side port only
- G PVB2*(F)*SFW-20-C(M)-11 Thru shaft only
- H Install gasket with small end of teardrop hole pointing in direction of compensator adj plug.
- J Model PVB 29 compensator pressure adjustment shall not exceed 2000 psi.

Model PVB20/29

Model Code	Panagon		OEM	
	Panagon	OEM	Panagon	OEM
PVB20-(F)RS-20-C(M)-(*)-11	PS73	942169		
PVB20-(F)LS-20-C(M)-(*)-11	PS75	942170		
PVB29-(F)RS-20-C(M)-(*)-11	PS121	942171		
PVB29-(F)RS-20-C(M)-(*)-11	PS122	942172		
PVB20-(F)RSF-(*)-20-C(M)-11	PS1026	942241		
PVB20-(F)LSF-(*)-20-C(M)-11	PS1025	942242		
PVB29-(F)RSF-(*)-20-C(M)-11	PS1023	942243		
PVB29-(F)LSF-(*)-20-C(M)-11	PS1024	942244		
M-MFB20-U-10	PS1612	938383		
M-MFB29-U-10	PS2404	941470		
PVB45A-(F)RSF(*)-10-CA-11	PS1020	942285		

Model Code	Panagon		OEM		Panagon		OEM	
	Panagon	OEM	Panagon	OEM	Panagon	OEM	Panagon	OEM
PVB 20	PS577437	362027						
PVB 29			PS199	362029	PS82633	322903	PS778	300048
PVB 45A	PS1632	387534						

Model Code	Panagon		OEM	
	Panagon	OEM	Panagon	OEM
TD	PS94	362135		
TD	PS1615	352159	PS1978	246353
			PS79762	005806
PVB 2*	PS812	245979	PS1978	246353
PVB 2*	PS793	282880		
TD	PS1342	362136		
M*B 2*	PS1607	266189		
M*B 2*	PS1256	285408		

Model Code	Panagon		OEM		Panagon		OEM	
	Panagon	OEM	Panagon	OEM	Panagon	OEM	Panagon	OEM
PVB 20	PS126	250688	PS576464	941883	PS67	938274		
M*B 20			PS576446	941884	PS1188	938281		
PVB 29	PS137	259458	PS576466	941888	PS1240	938275		
M*B 29	PS1582	287454	PS5811136	923326	PS1939	922999		
PVB 45A	PS1635	383501	PS576524	942284	PS1191	938074		

Model Code	Panagon		OEM		Panagon		OEM	
	Panagon	OEM	Panagon	OEM	Panagon	OEM	Panagon	OEM
PVB 20								
PVB 29	PS87	388745	PS1170	353230	PS89	36924		
PVB 45A								

Model Code	Panagon		OEM		Panagon	OEM	Pressure Range (PSI)
	Panagon	OEM	Panagon	OEM			
C	PS576864	942158	PS37	239371			250-3000 (PVB 5) (K) 250-2000 (PVB 6)
CM	PS576865	942159		264693			250-1500
CG	PS137530	942480	PS37	239371			
CMG	PS2205	941353	PS5818734	264693			

Model Code	Panagon		OEM	
	Panagon	OEM	Panagon	OEM
All Pressure Compensated	PS1467	404751	PS1466	227407
H/M Only	PS1467	195060	PS1457	227401

Model PVB20/29

(F3) - PVB 2 * - (F) * S F (*) - 20 - * - (*) - 11

1 2 3 4 5 6 7 8 9 10 11 12

- | | |
|--------------------------------------------------------------------------------------------------------------------------------------------------------------------------------------------------------------------------------------------------------------------------------------------------------------------------------------------------------------------------------------------------------------------------------------------------------------------------------------------------------------------------------------------------------------------------------------------------|--------------------------------------------------------------------------------------------------------------------------------------------------------------------------------------------------------------------------------------------------------------------------------------------------------------------------------------------------------------------------------------------------------------------------------------------------------------------|
| <p>1 Special Seals
F3 Multi-fluid capability - Viton seals</p> <p>2 Model
Variable displacement pump, inline piston design</p> <p>3 Flow Rating @1800
20 USgpm
29 USgpm</p> <p>4 Mounting
F Foot Bracket
(Omit for flange mount)</p> <p>5 Rotation
R Right hand (CW)
L Left hand (CCW)</p> <p>6 Swash Plate Movement
S One side of center</p> <p>7 Optional Features
Flange Connected
(Omit for Oring Port)</p> | <p>8 Shaft End
W Side Port
X Thru - Shaft - Side Port
(Omit for Rear Port)</p> <p>9 Pump Design</p> <p>10 Control Type
Pressure Compensator
C 250-3000 psi
250-2000 psi
CM 250-1500 psi
CVP Pressure Limiter Load Sensing</p> <p>11 Compensator Variation Options
C Adjustable Maximum Stop</p> <p>12 Control Design Number</p> |
|--------------------------------------------------------------------------------------------------------------------------------------------------------------------------------------------------------------------------------------------------------------------------------------------------------------------------------------------------------------------------------------------------------------------------------------------------------------------------------------------------------------------------------------------------------------------------------------------------|--------------------------------------------------------------------------------------------------------------------------------------------------------------------------------------------------------------------------------------------------------------------------------------------------------------------------------------------------------------------------------------------------------------------------------------------------------------------|

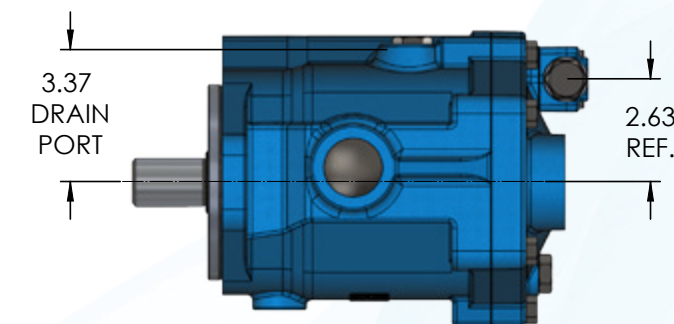
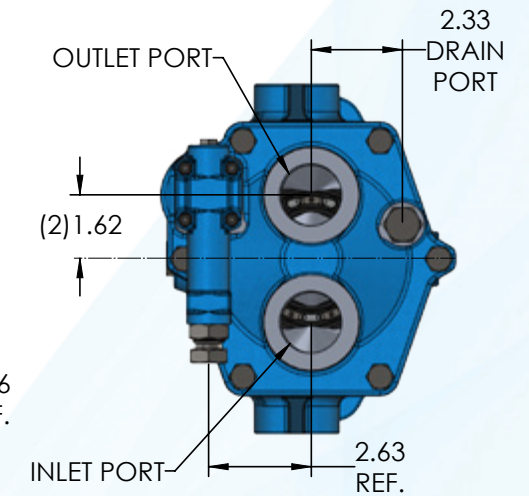
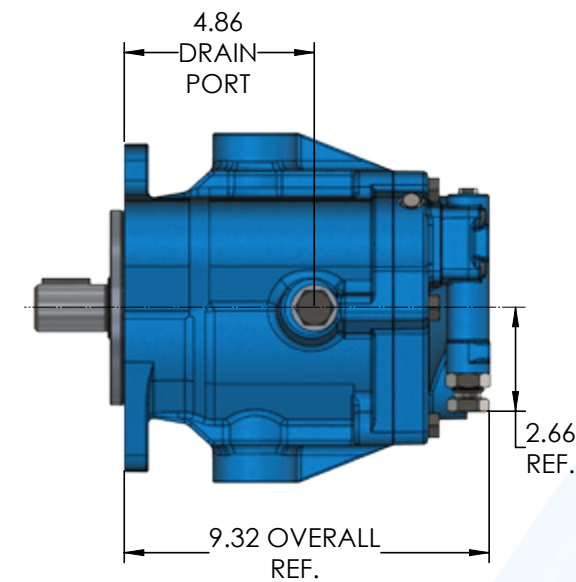
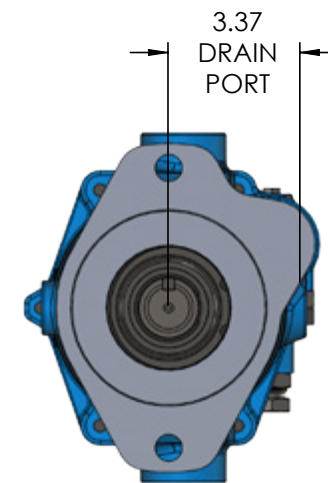
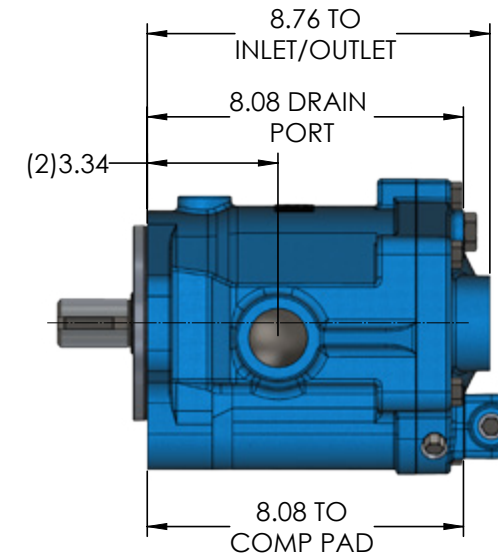

Model PVB45a

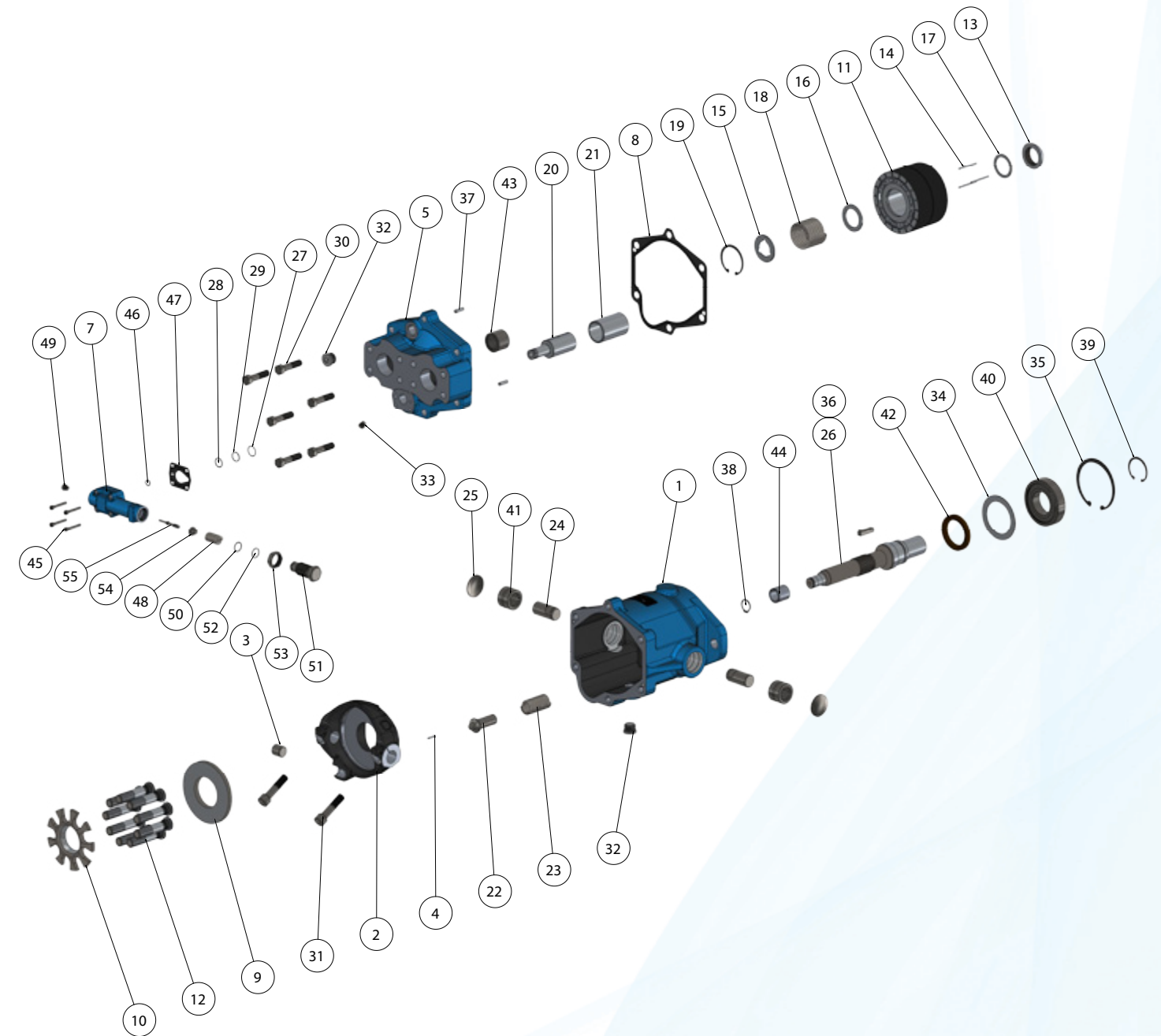
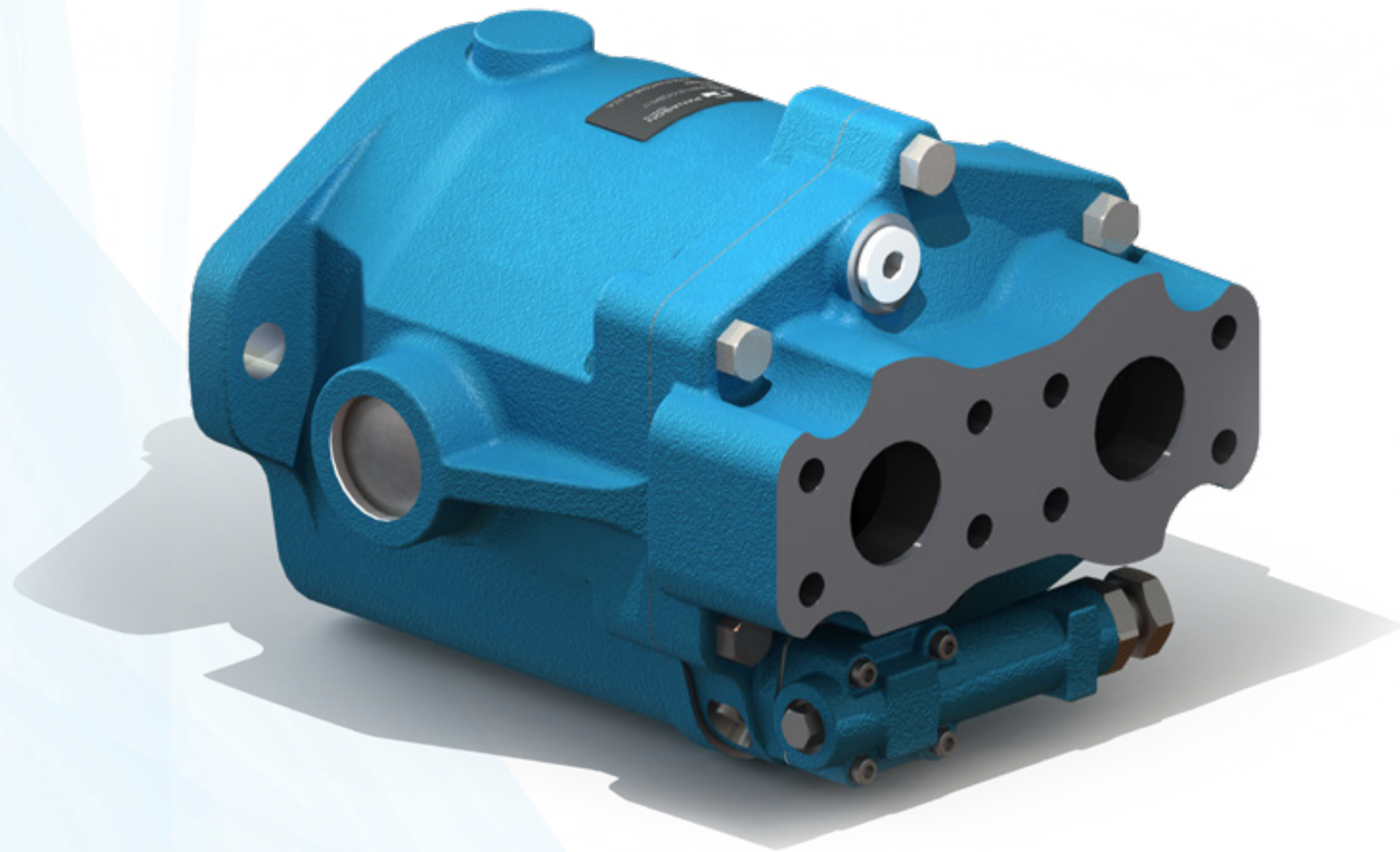

Model PVB45a

ITEM	PART NUMBER		QTY	NOTE	DESCRIPTION
	Panagon	OEM			
1	PS199	362029	1		Housing
2	PS1632	387534	1		Yoke
3	PS82633	322903	1		Roller
4	PS778	300048	1		Roller Pin
5	PS1020	942285	1	C	Valve Block
6	PS1459	164432	1	C	Instruction Plate
7	PS576862	932964	1	B/D	Compensator
8	PS193	245976	1	A	Gasket
9	PS999	239335	1	E	Swashplate
10	PS1634	387529	1	E	Shoe Plate
11	PS1635	383501	1	E	Cylinder Block
12	PS576524	942284	9	E	Piston/Shoe S/A
13	PS1591	283993	1	E	Spherical Washer
14	PS143	248836	3	E	Pin
15	PS147	244931	1	E	Lift Limiter
16	PS146	238780	1	E	Thrust Washer
17	PS1218	238836	1	E	Back-Up Washer
18	PS1297	246386	1	E	Spring
19	PS783	194025	1	E	Retaining Ring
20	PS112	379792	1	B	Control Rod
21	PS113	379793	1	B	Control Piston
22	PS93	245975	1	B	Seat
23	PS92	294079	1	B	Inner Spring
24	PS87	388745	2		Pintle
25	PS89	36924	2		Pintle Cover
26	PS94	362135	1		Drive Shaft
27	PS1617	185638	1	C	Retaining Ring
28	PS5811361	104166-015	1	A	O-Ring
29	PS5811360	8770-015	1		Back-Up Ring
30	PS109	001295	6		Screw
31	PS702	001116	2		Screw
32	PS5814121	115046-008	2		O-Ring Plug S/A
33	PS8123	115046-002	1		O-Ring Plug S/A
34	PS716	194878	1		Seal Retainer
35	PS100	117506	1		Retaining Ring
36	PS1978	246353	1		Key
37	PS780	003913	2		Pin
38	PS1241	193734	1		Retaining Ring
39	PS99	117507	1		Retaining Ring
40	PS98	283090	1		Bearing
41	PS1170	353230	2		Bearing
42	PS136821	295262	1	A	Shaft Seal
43	PS106	251108	1	C	Bearing
44	PS1242	292499	1		Shaft Spacer

ITEM	PART NUMBER		QTY	NOTE	DESCRIPTION
	Panagon	OEM			
45	PS1485	010358	4	E	Screw
46	PS134777	104166-011 (262331)	1	E	"O"-Ring
47	PS90309	913451	1	A/D/F	Gasket
48	PS1520	400256	1	D	Spring
49	PS8123	115046-002 (398071)	1	D	"O"-Ring Plug S/A
50	PS134800	104166-015 (173792)	1	A/D	"O"-Ring
51		See Table	1	D	Adjusting Plug
52	PS577672	8770-015 (186947)	1	D	Back-Up Ring
53	PS91024	937039	1	D	Jam Nut
54	PS36	234204	1	D	Seat
55		See Table	1	D	Spool

Table - Pressure Compensator						
Model Code	Panagon	OEM	Panagon	OEM	Panagon	OEM
Model	Comp. S/A		Spool		Adjusting Plug	
PVB45A-CG	PS1622	942287	PS35	356986	PS39	360430
PVB45A-CAG	PS1621	942444	PS1626	296234	PS1623	412940

- A Included in PS985 / 919683 Seal Kit (F3 equivalent 919847)
- B Used with compensator control only
- C Included in Valve Plate S/A
- D Included in Pressure Compensator Kit
- E Included in Rotating Group
- F Install gasket with small end of teardrop hole pointing in direction of compensator adj plug

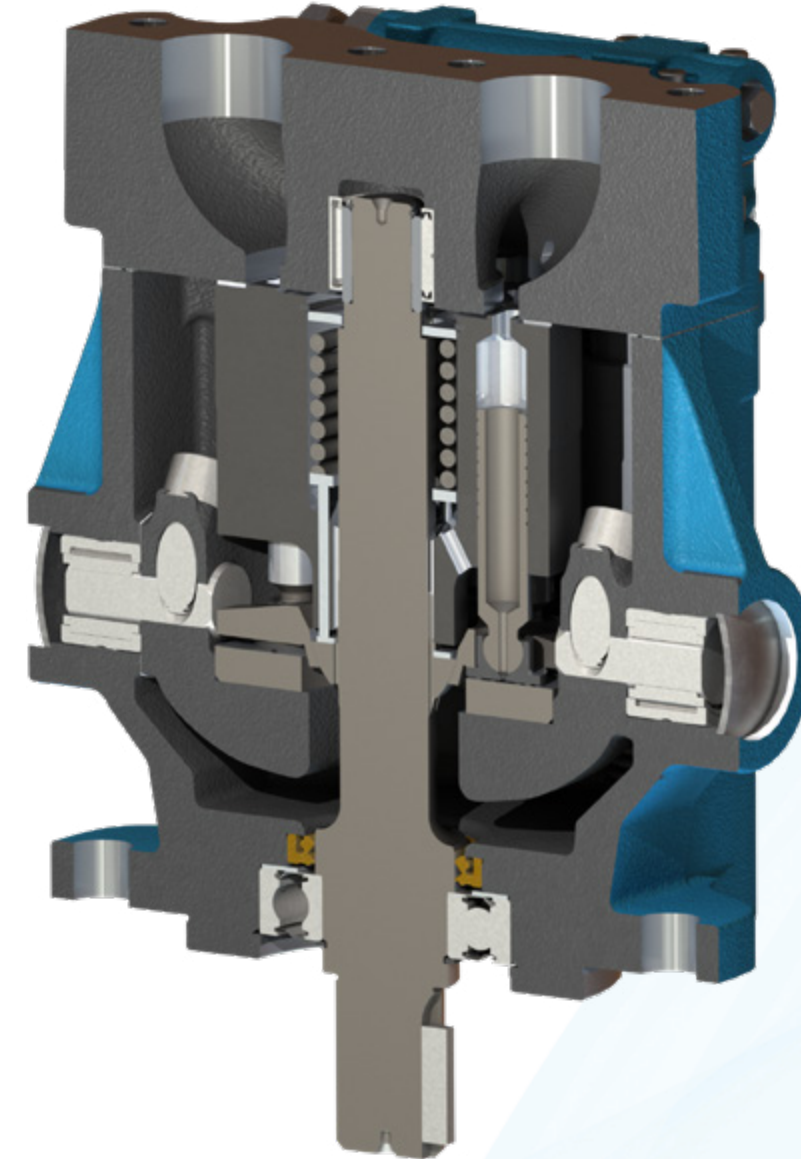

Model PVB45a Variable Inline

(F3) PVB 45 A - (F) R S F - 1 * - CA (G) - **

1 2 3 4 5 6 7 8 9 10 11 12

- | | |
|-------------------------------------------------------------------------------------------------------------------------------------------------------------------------------------------------------------------------------------------------------------------------------------------------------------------------------------------------------------------------------------------------------------------------------------------------------------------------------------------------------------|--------------------------------------------------------------------------------------------------------------------------------------------------------------------------------------------------------------------------------------------------------------------------------------------------------------------------------|
| <p>1 Special Seals
F3 Multi-fluid capability - Viton seals</p> <p>2 Model
Variable displacement pump, inline piston design</p> <p>3 Flow Rating @1800
45 USgpm</p> <p>4 Medium Pressure Design</p> <p>5 Mounting
F Foot Bracket
(Omit for flange mount)</p> <p>6 Rotation
Viewing from shaft end
R Right hand (CW)</p> <p>7 Swash Plate Movement
S One side of center</p> | <p>8 Port Connections
F SAE 4 - bolt flange</p> <p>9 Pump Design</p> <p>10 Pressure Compensator
Medium pressure (200-1000 psi)</p> <p>11 Remote Control of Compensator</p> <p>12 Control Design
11 CA Compensator
20 CAG Compensator</p> |
|-------------------------------------------------------------------------------------------------------------------------------------------------------------------------------------------------------------------------------------------------------------------------------------------------------------------------------------------------------------------------------------------------------------------------------------------------------------------------------------------------------------|--------------------------------------------------------------------------------------------------------------------------------------------------------------------------------------------------------------------------------------------------------------------------------------------------------------------------------|

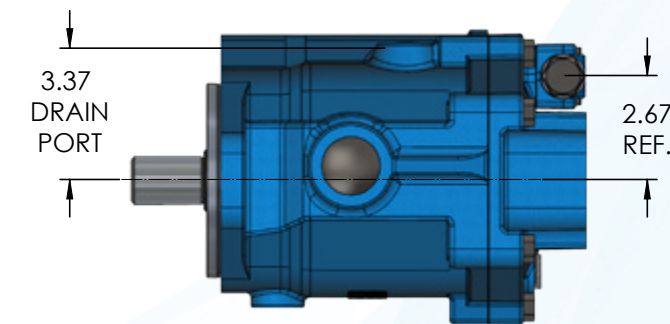
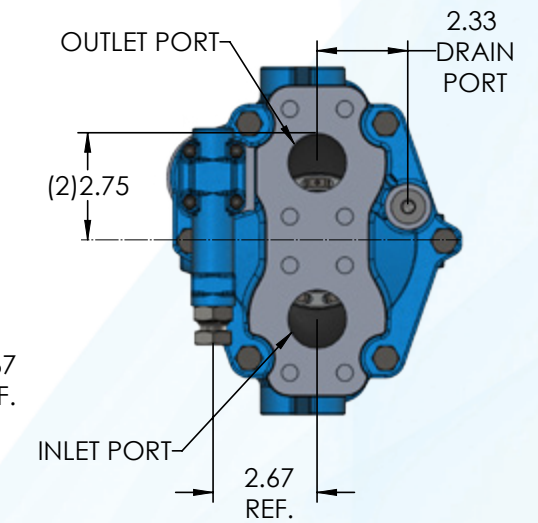
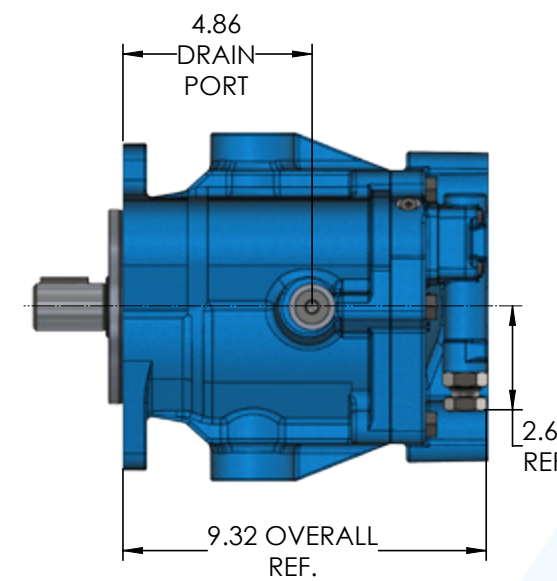
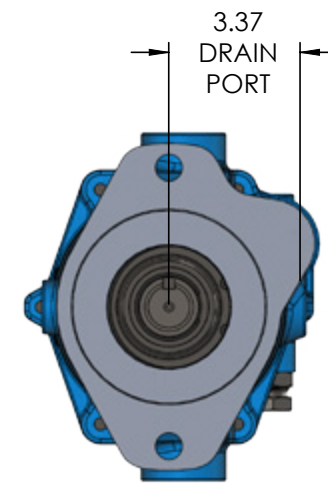
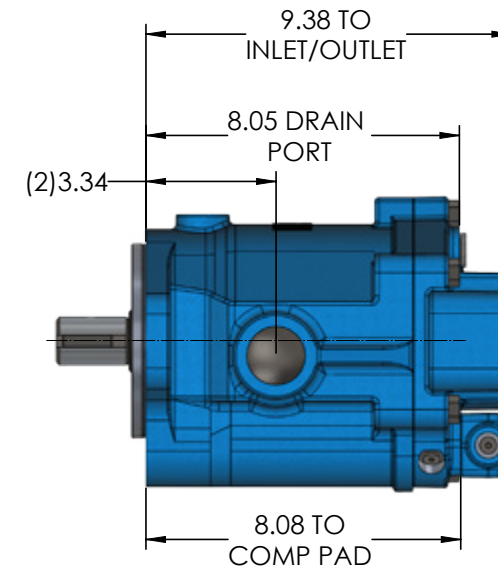

Model PVB45

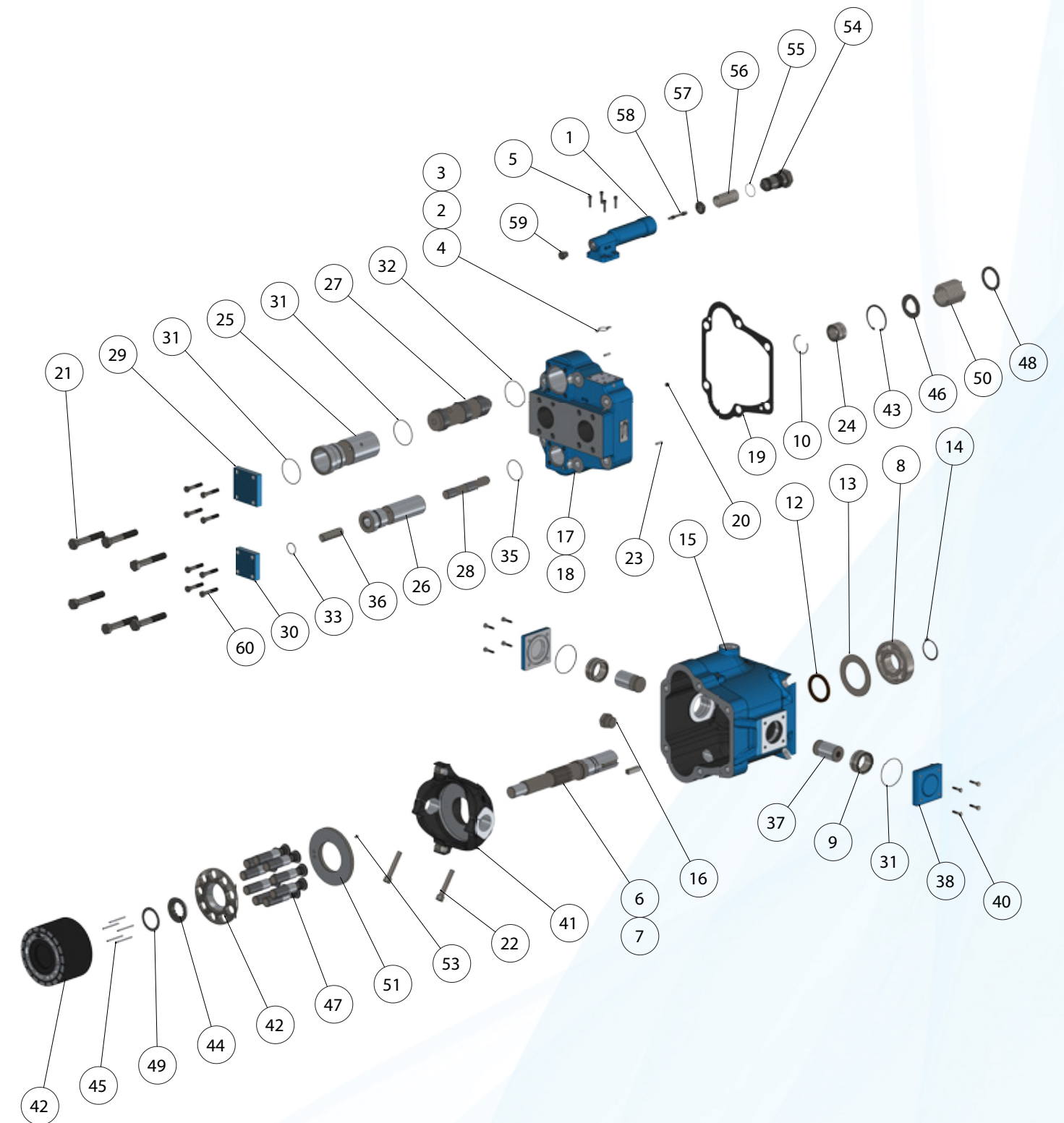
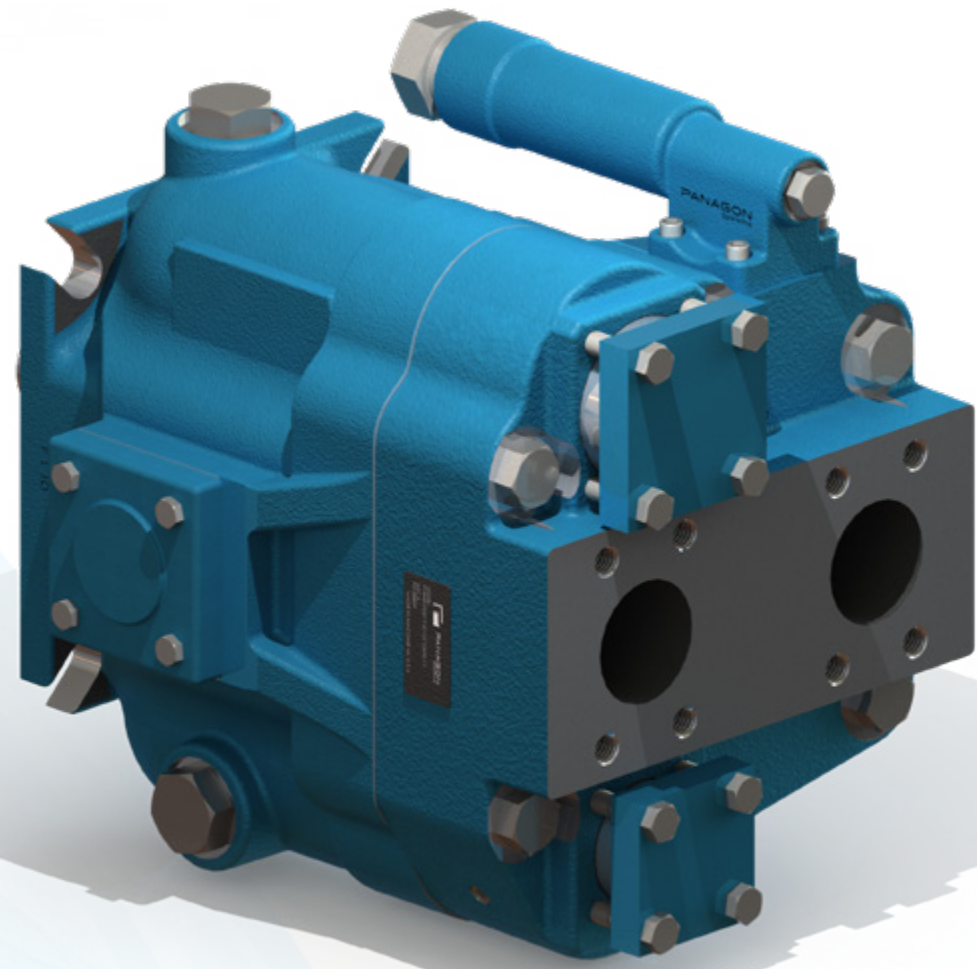

Model PVB45

ITEM	PART NUMBER		QTY	NOTE	DESCRIPTION
	Panagon	OEM			
1	PS3218	247355	1	A	Compensator (C)
1	PS3218	247355	1	A	Compensator (CM)
2	PS135150	154013 (-116)	1	C	O-Ring
3	PS134765	154004 (-010)	1	C	O-Ring
4	PS134772	154005 (-011)	1	C	O-Ring
5	PS3219	001031	4	A	Screw
6	PS988	317654	1		Drive Shaft
7	PS1044	247101	1		Key
8	PS1019	283662	1		Bearing S/A
9	PS1312	402152	2		Bearing S/A
10	PS1370	400270	1	B	Retaining Ring
11	PS1347	102835	1		Retaining Ring
12	PS136832	287458	1	C	Shaft Seal
13	PS1640	273385	1		Seal Retainer
14	PS1348	171545	1		Retaining Ring
15	PS1641	318267	1		Housing
15	PS1642	387826	1		Housing - Flange Mount
16	PS1579	187087	1		O-Ring Plug
17	PS2286	352155	1		Valve Block RH Rotation
17	PS2335	351099	1		Valve Block LH Rotation
18	PS1355	318272	1	C	Gasket
19	PS79798	007074	2	B/F	Plug
20	PS1647	295415	6		Screw
21	PS287	001117	2		Screw
22	PS780	003913	2		Pin
23	PS1313	257045	1	B	Bearing S/A
24	PS4244	354856	1		Sleeve - Control
25	PS8780	349747	1		Sleeve - Bias
26	PS4243	349748	1		Piston - Control
27	PS8779	342569	1		Piston - Bias
28	PS8776	342570	1		Cover
29	PS8777	342571	1		Cover
30	PS135311	161979	2	C	O-Ring
31	PS135332	199821	1	C	O-Ring
32	PS135171	170441	1	C	O-Ring
33	PS135241	166757	1	C	O-Ring
34	PS135262	151668	1	C	O-Ring
35	PS8778	349967	1		Bias Spring
36	PS1352	318269	1		Pintle
37	PS8791	361068	1		Pintle Cover

ITEM	PART NUMBER		QTY	NOTE	DESCRIPTION
	Panagon	OEM			
38	PS135346	199823	2	C	O-Ring
39	PS1646	212267	8		Screw
40	PS1443	318268	1		Yoke and Roller S/A
41	PS1295	344064	1	D	Cylinder Block
42	PS1354	126911	1	D	Retaining Ring
43	PS992	241541	1	D	Spherical Washer
44	PS156	248883	5	D	Pin
45	PS974	246017	1	D	Lift Limiter
46	PS576443	923189E	9	D	Piston Shoe S/A
47	PS975	253665	1	D	Thrust Washer
48	PS976	253664	1	D	Back-Up Washer
49	PS1298	282557	1	D	Spring
50	PS998	374757	1	D	Swashplate
51	PS994	266112	1	D	Shoe Plate
52	PS2018	201408	1	D	Roll Pin
53	PS3216	297950	1	A	Adjusting Plug
54	PS134863	187000	1	A	O-Ring
55	PS3217	245087	1	A	Spring (C)
56	PS3222	245087	1	A	Spring (CM)
56	PS2105	247354	1	A	Seat
57	PS3220	341114	1	A	Spool
58	PS8123	398071	1	A	O-Ring Plug
59	PS8775	212332	8		Screw

A Included in control kits PS2089 / 942112 "C" and PS3214 / 942133 "CM"

B Included in Valve Plate S/A

C Included in PS142 / 919890 Seal Kit

D Included in rotating group kit PS98 / 938279

E F3 equivalent gasket kit PS1422 / 919891

F 3 required for LH

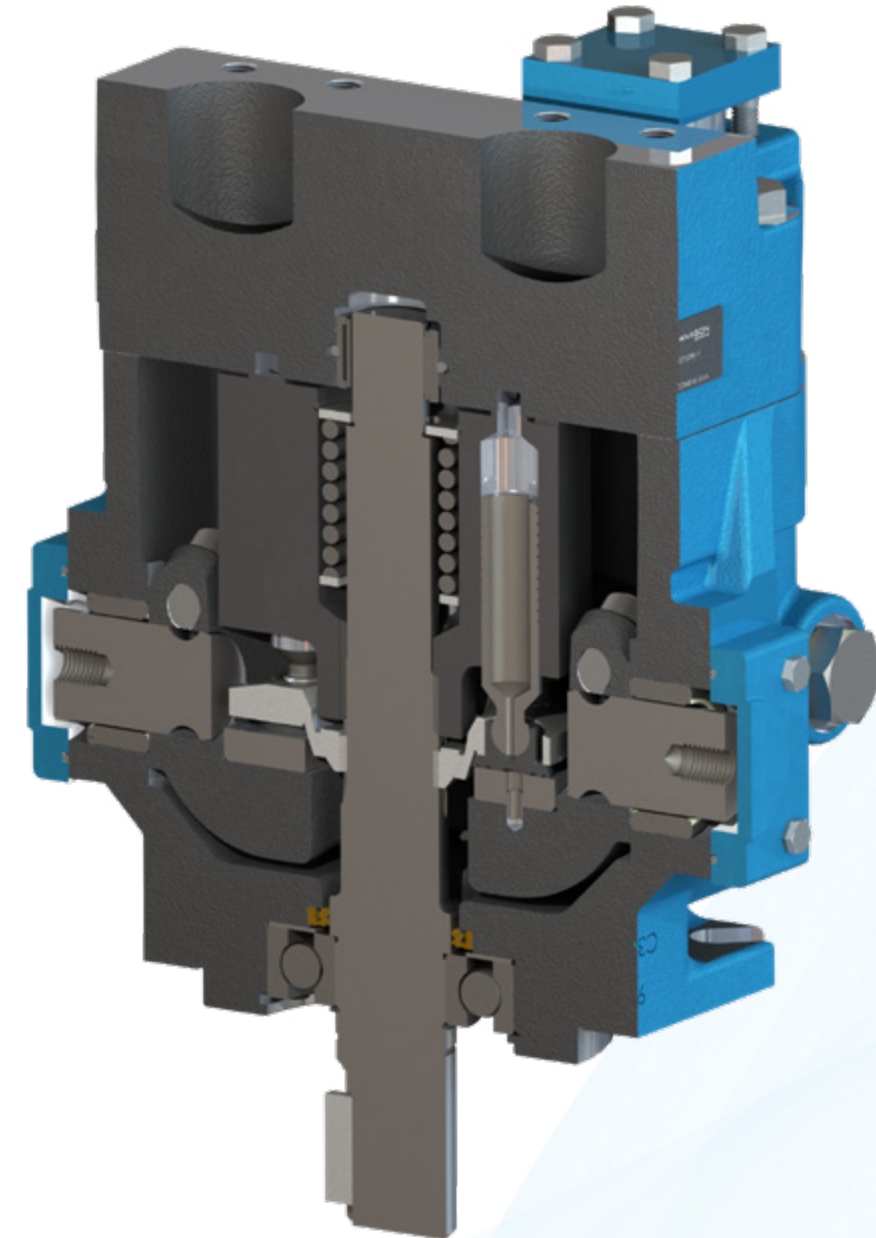

Model PVB45

(F3) - PVB 45 - (F) * S F * - 20 - C (*) (*) - 11 (S67)

1 2 3 4 5 6 7 8 9 10 11 12 13

- | | |
|-------------------------------------------------------------------------------------------------------------------------------------------------------------------------------------------------------------------------------------------------------------------------------------------------------------------------------------------------------------------------------------------------------------------------------------------------------------------------------------------------------------|-----------------------------------------------------------------------------------------------------------------------------------------------------------------------------------------------------------------------------------------------------------------------------------------------------------------------------------------------------------------------------------------------------------------------------------------------------------------------------|
| <p>1 Special Seals
Variable displacement pump, inline piston design</p> <p>2 Model
Variable displacement pump, USgpm inline series</p> <p>3 Flow Rating @ 1800 RPM
45 USgpm</p> <p>4 Mounting
F Foot bracket (Omit for flange mount)</p> <p>5 Rotation
Viewing from shaft end
L Left hand (CCW)
R Right hand (CW)</p> <p>6 Swash Plate Movement
S One side of center</p> <p>7 Port Connections
F SAE 4-bolt flange</p> | <p>8 Optional Features
W Side port
X Thru shaft</p> <p>9 Pump Design</p> <p>10 Control Type
C Compensator (250-3000 psi)
CM Compensator (150-1500 psi)</p> <p>11 Compensator Control Spacers
Omitted - 100% flow
9 90% flow
8 80% flow
7 70% flow
6 60% flow</p> <p>12 Control Design</p> <p>13 Option
Adapter plate interchangeability between 10 and 11 design foot mounted models.</p> |
|-------------------------------------------------------------------------------------------------------------------------------------------------------------------------------------------------------------------------------------------------------------------------------------------------------------------------------------------------------------------------------------------------------------------------------------------------------------------------------------------------------------|-----------------------------------------------------------------------------------------------------------------------------------------------------------------------------------------------------------------------------------------------------------------------------------------------------------------------------------------------------------------------------------------------------------------------------------------------------------------------------|

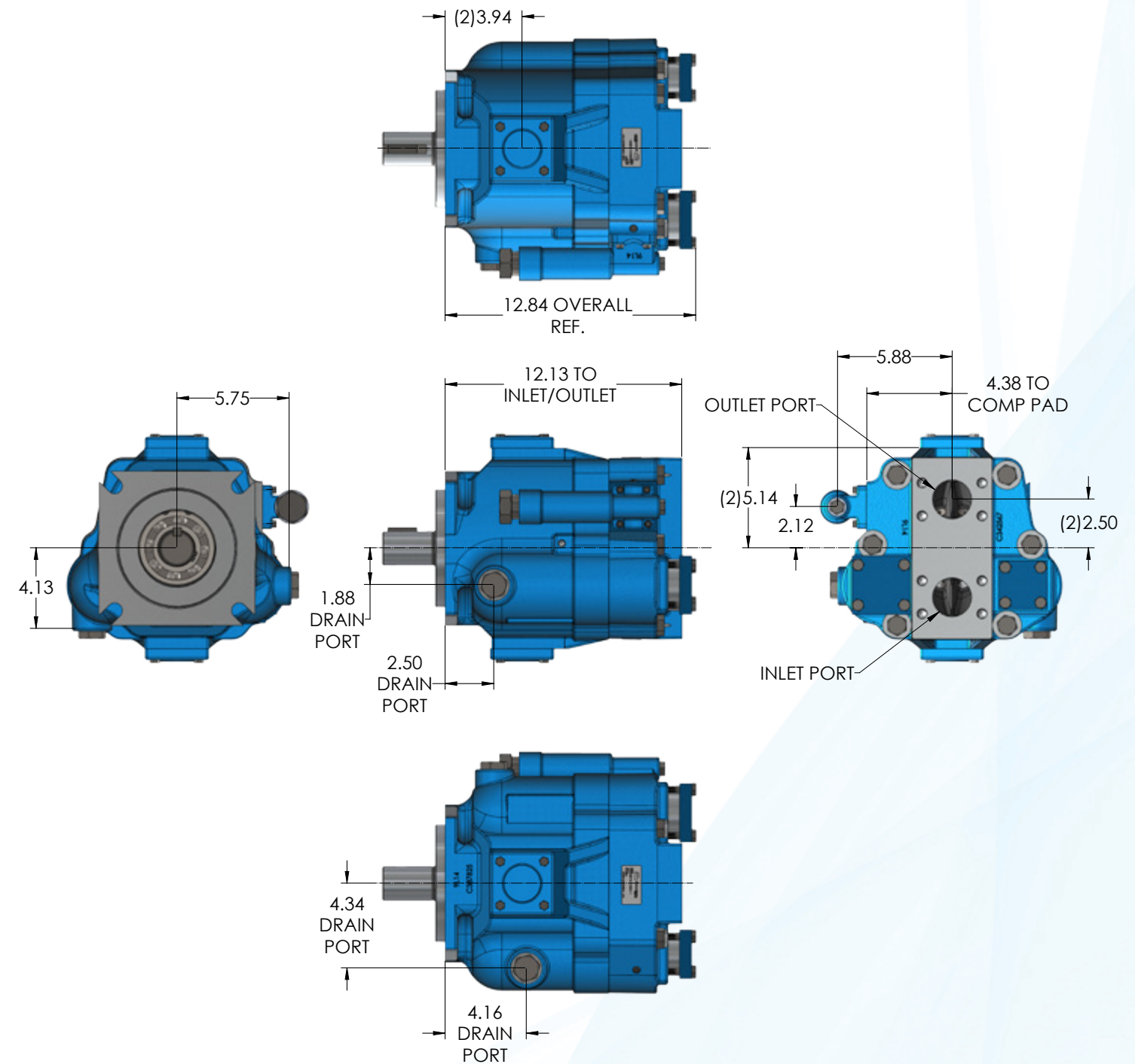

Model PVB90

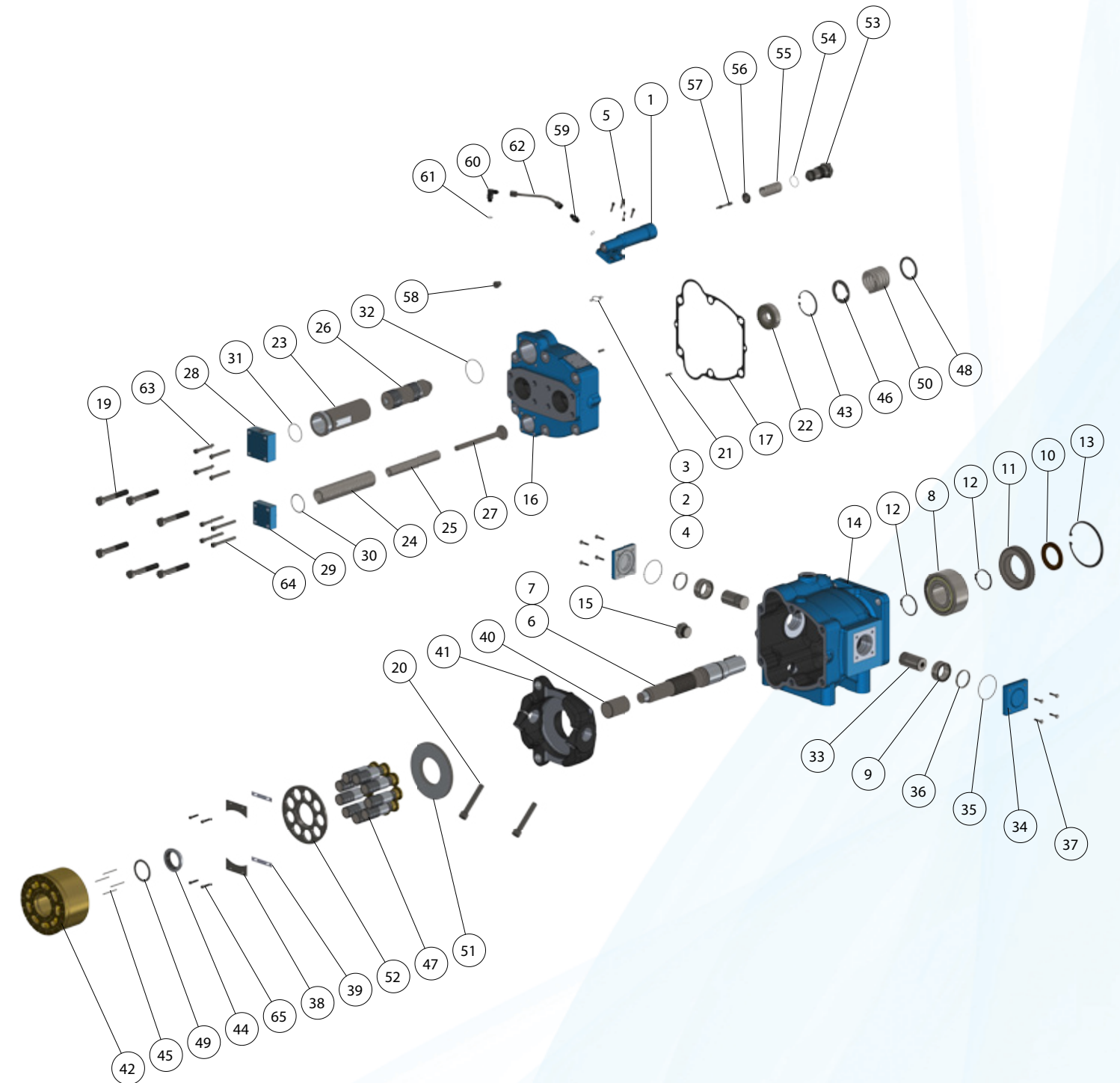
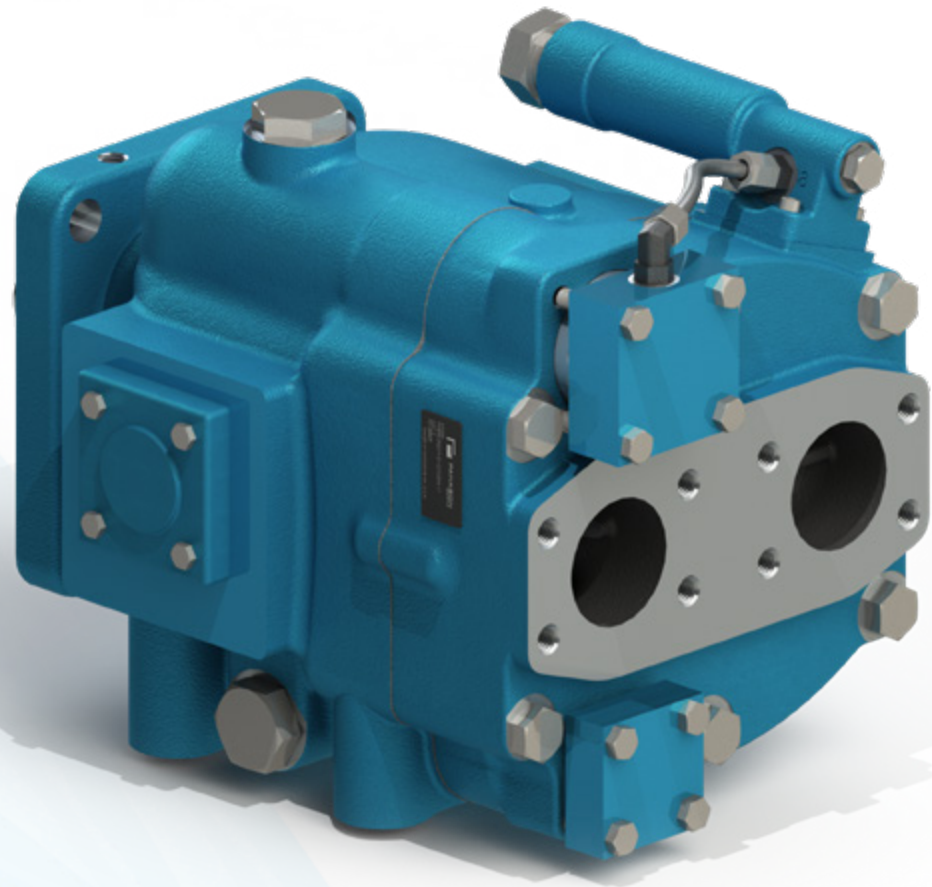

Model PVB90

ITEM	PART NUMBER		QTY	NOTE	DESCRIPTION
	Panagon	OEM			
1	PS3225	307244	1	A	Compensator (C)
1	PS3225	307244	1	A	Compensator (CM)
2	PS135150	154013	1	C	O-Ring
3	PS134765	154004	1	C	O-Ring
4	PS134772	154005	1	C	O-Ring
5	PS3219	001031	4	A	Screw
6	PS1046	289220	1		Drive Shaft
7	PS1044	247101	1		Key
8	PS1043	287783	1		Bearing S/A
9	PS1312	402152	2		Bearing S/A
10	PS-136815	321604	1	C	Shaft Seal
11	PS8801	286873	1		Seal Retainer
12	PS8802	121555	2		Retaining Ring
13	PS8800	132474	1		Retaining Ring
14	PS82326	295080	1		Housing
15	PS7838	181765	2		O-Ring Plug
16	PS82330	295214	1		Valve Block RH Rotation
16	295214	297951	1		Valve Block LH Rotation
17	PS7713	248450	1	C	Gasket
18	PS1782	007076	1	B	NPT Plug
19	PS6616	011170	6		Screw
20	PS8805	298172	2		Screw
21	PS8411	112934	2		Pin
22	PS2453	271537	1	B	Bearing S/A
23	PS7248	295275	1		Sleeve - Control
24	PS82338	295679	1		Bias Spring - Outer
25	PS82337	295678	1		Bias Spring - Inner
26	PS7247	292396	1		Piston - Control
27	PS7249	295078	1		Bias Seat
28	PS82327	295085	1		Cover - Control
29	PS82325	295077	1		Cover - Bias
30	PS7712	295076	1	C	Bias Gasket
31	PS135269	194699	1	C	O-Ring
32	PS135339	199822	1	C	O-Ring
33	PS1814	312656	2		Pintle
34	PS8791	361068	2		Pintle Cover
35	PS135346	199823	2	C	O-Ring
36	PS8808	287184	2		Pintle Spacer
37	PS1646	212267	8		Screw
38	PS8807	287183	2		Lift Plate
39	PS6324	287285	2		Shim Stock
40	PS5265	263039	1		Lift Limiter Sleeve

ITEM	PART NUMBER		QTY	NOTE	DESCRIPTION
	Panagon	OEM			
41	PS6314	295012	1		Yoke and Roller S/A
42	PS8810	325650	1	D	Cylinder Block
43	PS6315	190275	1	D	Retaining Ring
44	PS6321	248444	1	D	Spherical Washer
45	PS6320	248861	5	D	Pin
46	PS6316	263038	1	D	Lift Limiter
47	PS576462	942084	9	D	Piston Shoe S/A
48	PS6318	248567	1	D	Thrust Washer
49	PS8809	261437	1	D	Back-Up Washer
50	PS6317	249901	1	D	Spring
51	PS6323	287180	1	D	Swashplate
52	PS6322	325652	1	D	Shoe Plate
53	PS3216	297950	1	A	Adjusting Plug
54	PS134863	187000	1	A	O-Ring
55	PS3217	245087	1	A	Spring (C)
55	PS3222	285870	1	A	Spring (CM)
56	PS2105	247354	1	A	Seat
57	PS3220	341114	1	A	Spool
58	PS8123	398071	1	A	O-Ring Plug
59	PS81063	187003	1	A	Fitting
60	PS82437	307413	1	A	Elbow Fitting
61	PS136611	263495	2	A	O-Ring
62	PS82332	295274	1	A	Tube S/A
63	PS81264	212335	4		Screw
64	PS82011	275505	4		Screw
65	PS7948	001228	4		Screw

A Included in control kits PS3223 / 941184 "C" and PS3224 / 941185 "CM"

B Included in Valve Plate S/A

C Included in PS4104 / 919506 Seal Kit

D Included in rotating group kit PS1192 / 938291

E F3 equivalent gasket kit 938291

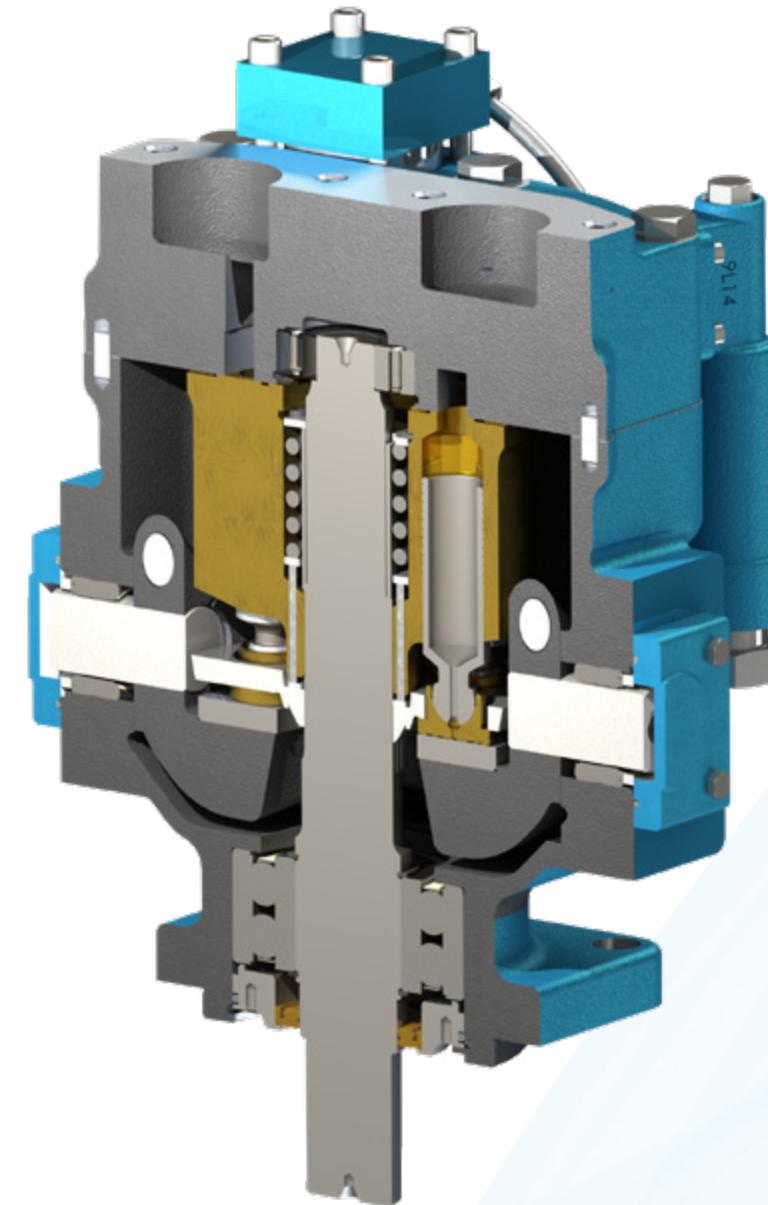

Model PVB90

PVB 90 - (F) * S F - 20 - C * - 1

1 2 3 4 5 6 7 8 9 10

- 1 **Model**
Variable displacement pump,
inline piston design
- 2 **Flow Rating @1800 RPM**
90 USgpm
- 3 **Mounting**
F Foot bracket
(Omit for flange mount)
- 4 **Rotation**
Viewing from shaft end
L Left hand
R Right hand
- 5 **Swash Plate Movement**
S One side of center
- 6 **Port Connections**
F SAE 4-bolt flange SAE 4 bolt
- 7 **Pump Design**

- 8 **Compensator Control**
- 9 **Compensator Piston Limited Space**
9 90%
8 80%
7 70%
6 60%
- 10 **Control Design Number**

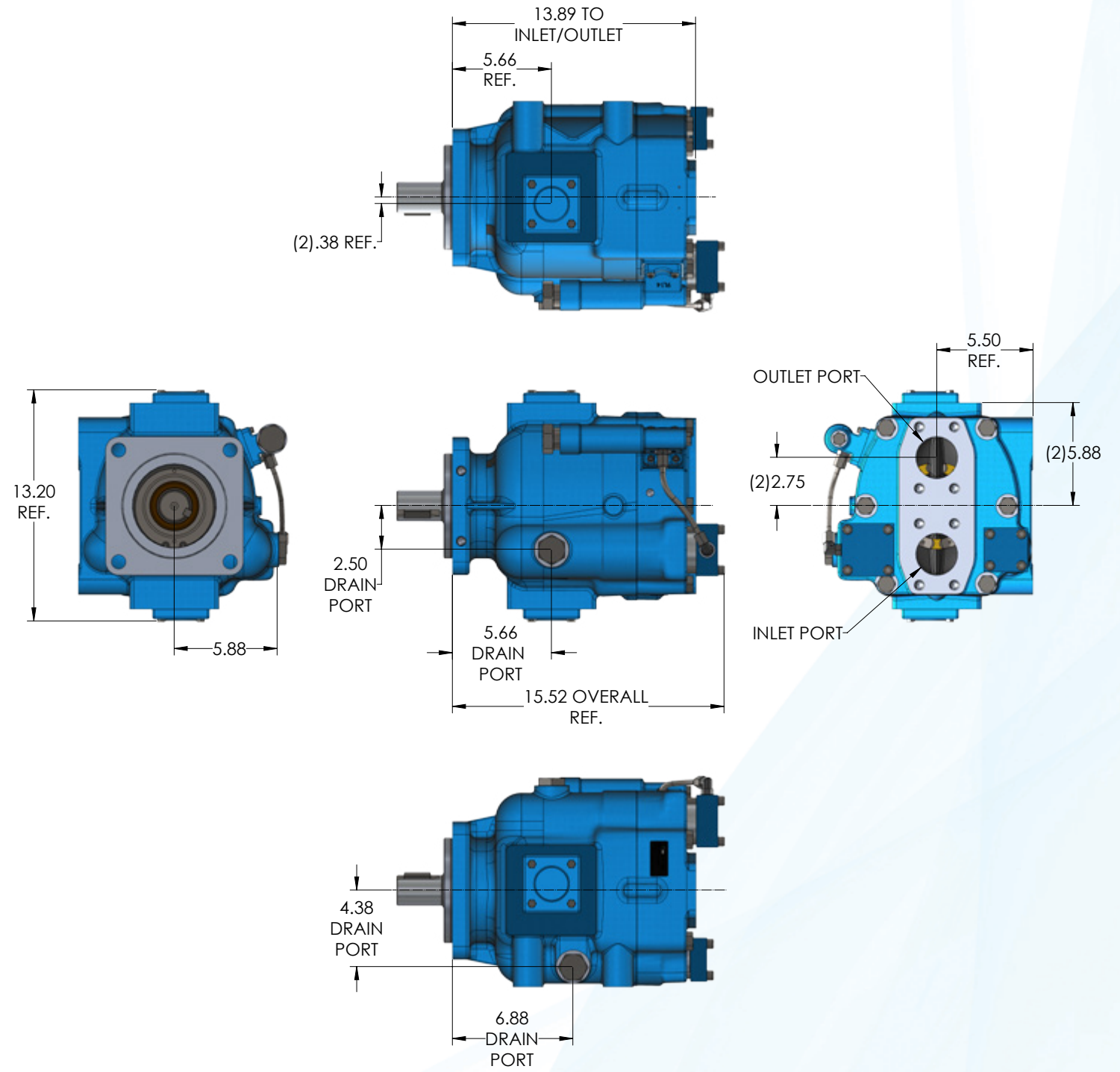



PROUDLY MANUFACTURED IN MACOMB, MICHIGAN

OEM Quality Hydraulic Pumps • OEM Quality Hydraulic Motors
OEM Quality Replacement Parts For: Vickers/Eaton, Rexroth and Caterpillar

51375 Regency Center Dr., Macomb, MI 48042 | Phone: 586-786-3920 | Fax: 586-786-7331
Email: sales@panagonsystems.com



WWW.PANAGONSYSTEMS.COM