



PANAGON
systems

HYDRAULIC PUMP MANUFACTURING

MVE PISTON MOTOR MODELS **BUILT BY US**

MVE 19

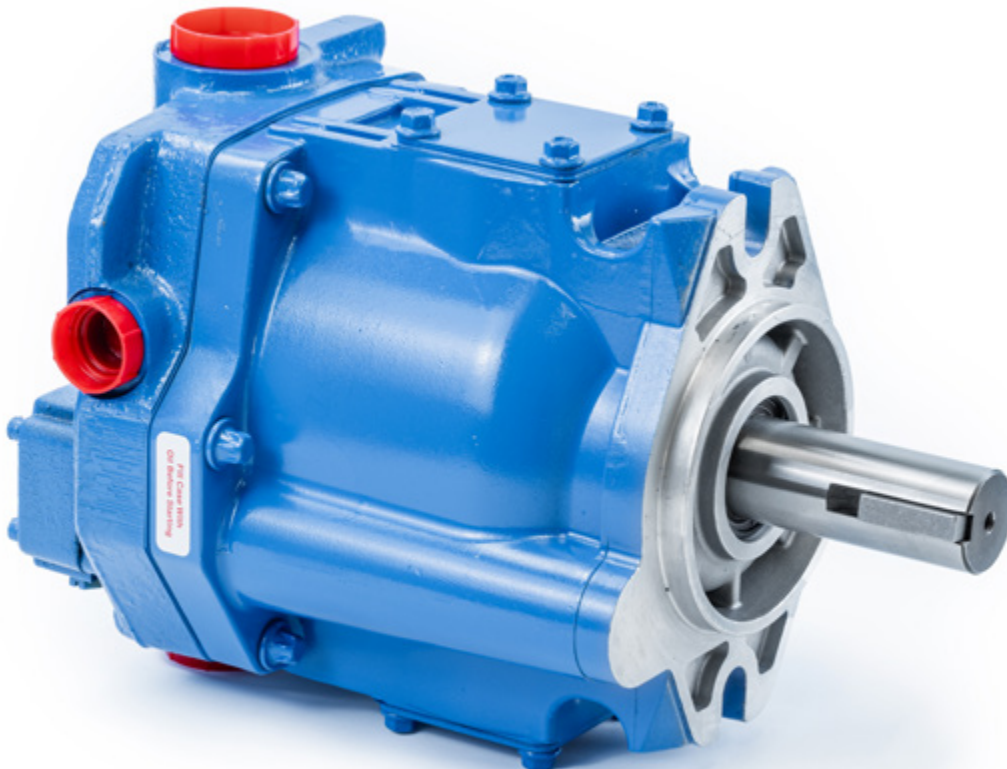

PARTS INFORMATION GUIDE

WWW.PANAGONSYSTEMS.COM



Founded nearly 35 years ago, Panagon Systems has remained a trusted company producing hydraulic parts on demand for a number of shops, manufacturers and industries. The company, located in Macomb, Michigan, is a hydraulic piston pumps and parts manufacturer, providing a vast variety of current and obsolete components. With a variety of CNC machines, Panagon produces finished product from raw materials. Which are then assembled, tested, painted and shipped from our facility. Panagon Systems attempts to fill the void OEM's create by manufacturing the phased out, expensive, unavailable pumps, motors and transmissions.

Model 19	2
Parts Identification	3
Parts Lists	4
Identification of Model Code	6

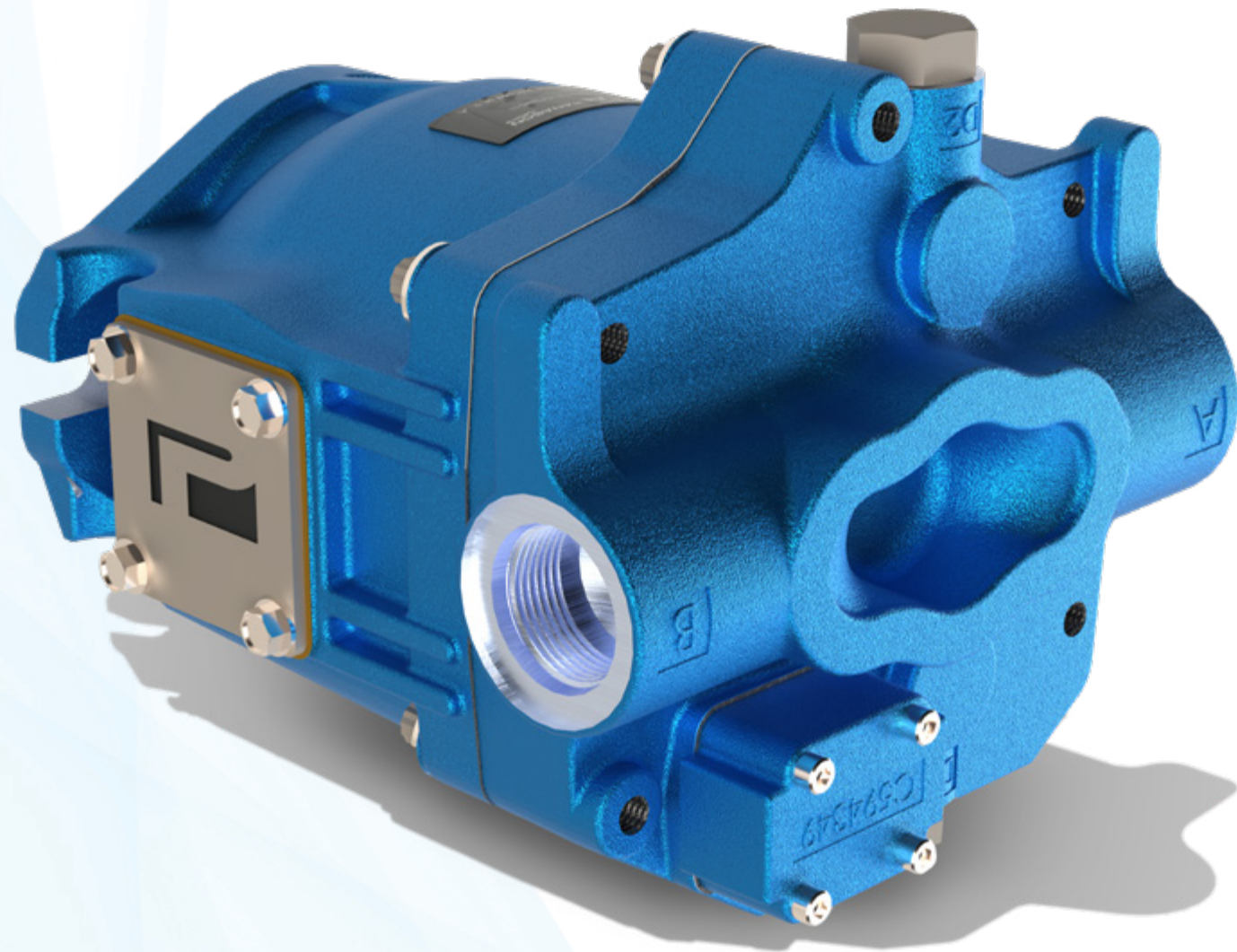

Model MVE19

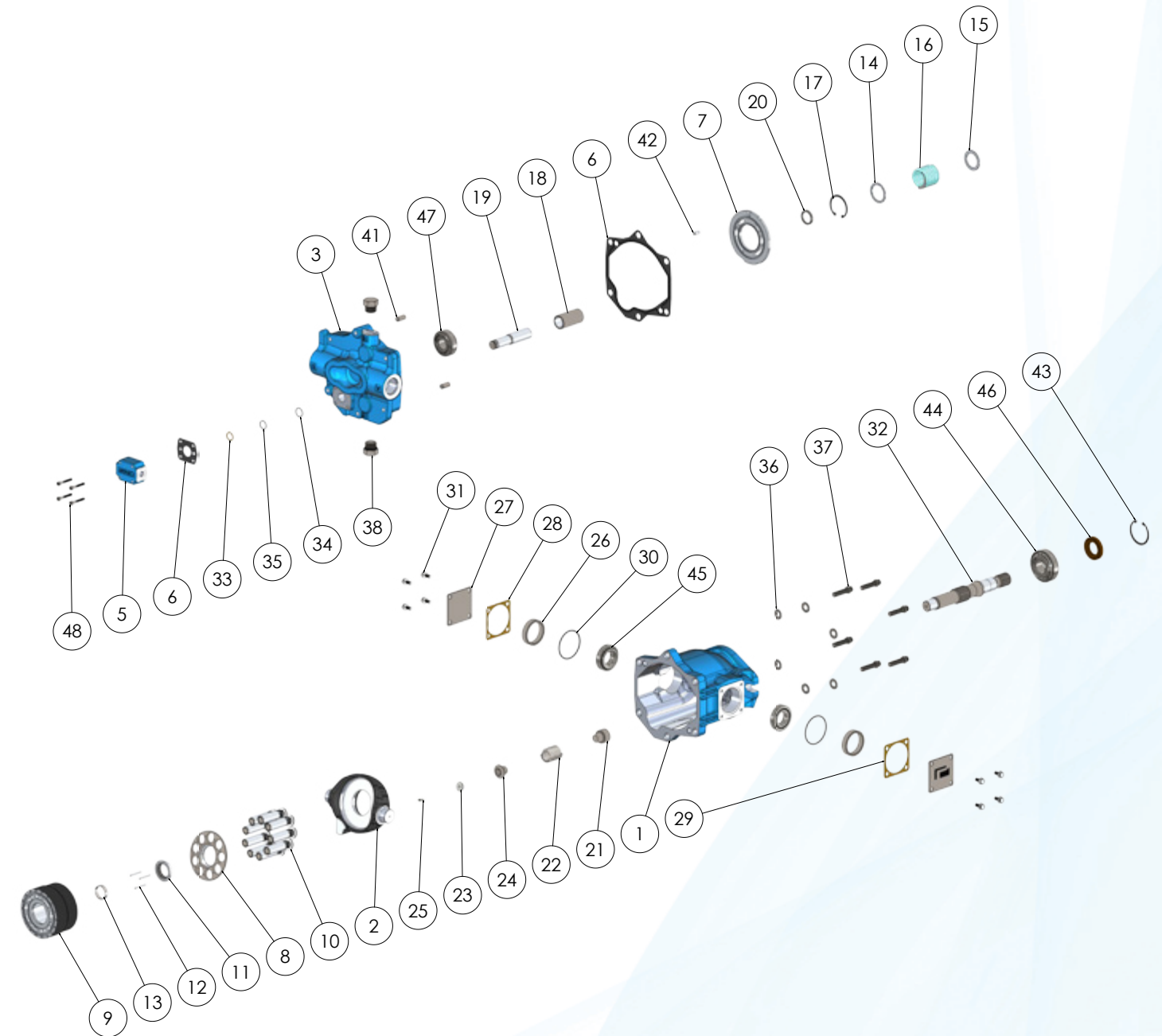

Model MVE19

ITEM	PART NUMBER		QTY	NOTE	DESCRIPTION
	Panagon	OEM			
1	PS11315	422308	1		Housing
2	PS86773	594341	1		Yoke
2	PS577320	409997	1		Yoke
3	PS86774	594346	1		Valve Block
3	PS87517	680780	1		Valve Block
4	PS1459	164432	1		Instruction Plate
5	PS86775	594348	1		Control Block
6	PS1417	423617	1	A	Gasket
7	PS3286	627147	1		Control Plate
8	PS1301	402650	1	D/E	Shoe Plate
9	PS1866	432213	1	D/E	Cylinder Block
10	PS576444	923939	9	D/E	Piston/Shoe Subasm
11	PS1300	402580	1	D/E	Spherical Washer
12	PS189	393841	3	D/E	Pin
12	PS1930	248810	3	D/E	Pin
13	PS1928	410050	1	D/E	Pin Retainer
14	PS1925	423368	1	D/E	Lift Limiter
15	PS1923	404932	1	D/E	Thrust Washer
16	PS2421	594799	1	D/E	Spring
16	PS2419	418271	1	D/E	Spring
17	PS7146	099907	1	D/E	Retaining Ring
18	PS137627	594354	1		Control Piston
18	PS577572	404958	1		Control Piston
19	PS86776	594353	1		Control Rod
20	See Table 1		1		Spacer
21	See Table 1		1		Seat
22	PS577881	594347	1		Inner Spring
22	PS86440	581075	1		Inner Spring
23	PS8096	409998	1		Seat Button
24	PS86438	581054	1		Yoke Stop
25	PS8097	162160	1		Roll Pin
26	PS10082	410053	2		Pintle Spacer
27	PS7568	416637	2		Pintle Cover
28	PS83763	416686	1	B/F	Pintle Shim (brown)
29	PS1997	923938	1	B/F	Pintle Shim Kit
30	PS135297	174140	2	A	"O"-Ring
31	PS8100	427172	8		Washer Hex Head Screw
32	PS1879	423415	1		Drive Shaft
32	PS1881	424544	1		Drive Shaft
33	PS135122	427682	1		"O"-Ring
34	PS1617	185638	1		Retaining Ring
35	PS5811360	197573	1	A	Back Up Ring
36	PS8007	233113	6		Washer
37	PS2454	427171	6		Torx Head Screw
38	PS6042	181792	1		"O"-Ring Plug Subasm #10
39	PS1996	942401	1	C/F	Shaft Spacer
40	PS1456	058303	1		Key
41	PS10080	429325	2		Roll Pin
42	PS10079	248910	1		Pin
43	PS1299	085560	1		Retaining Ring

ITEM	PART NUMBER		QTY	NOTE	DESCRIPTION
	Panagon	OEM			
44	PS1335	419627	1		Bearing
45	PS1337	417381	2		Bearing
46	PS136810	471965	1	A	Shaft Seal
47	PS1834	473914	1		Bearing
48	PS1485	010358	4		Socket Head Cap Screw
49	PS3266	436330	1		Gasket

Table 1 - Seat and Spacer				
Model Code	Panagon		OEM	
	Spring Seat		Panagon	OEM
MVE19*-30-M0-10			--	--
MVE19*-30-M7-10			PS5820101	629521
MVE19*-30-M9-10			PS86967	629522
MVE19*-30-M11-10	PS86777	594355	PS86968	629523
MVE19*-30-M13-10			PS5800637	629527
MVE19*-30-M14-10			PS5820102	595487
MVE19*-30-M15-10			PS5820103	629524
MVE19*-30-P7*-10	PS86437	581053	--	--
MVE19*-30-P9*-10	PS84566	500572	--	--

- A Included in Seal Kit PS90467 / 920248
- B Included in Pintle Shim Kit PS1997 / 923938
- C Included in Bearing Spacer Kit 942401
- D Included in Rotating Group (M**-10) PS2420 / 938092
- E Included in Rotating Group (P*-10) PS2418 / 923941
- F Refer to Overhaul Manual M-2844-S for Shaft End Play and Pintle Bearing Preload Shimming Procedure

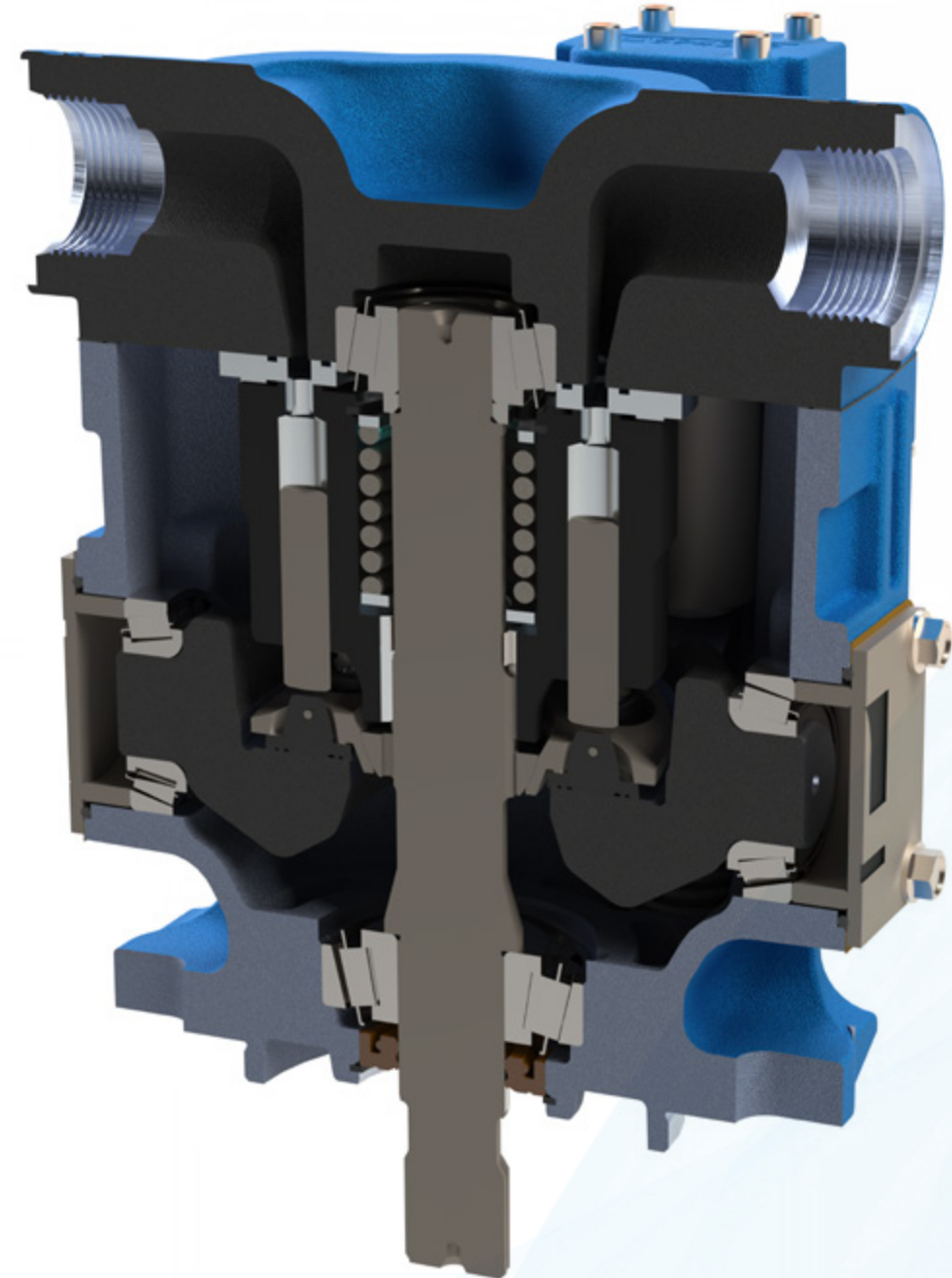

Model MVE19

M V E 1 9 (X) - 2 A 7 - 3 0
 1 2 3 4 5 6 7

- 1 Model Series**
MVE Motor, variable displacement, inline piston unit
- 2 Flow Rating @ 1800 rpm**
19 19 USgpm
- 3 Thru Shaft**
25T 32/64P (Flat root side fit, omit for standard single ended shaft)
- 4 Input Shaft**
2 SAE B-B splined
- 5 Lever Control Options (Viewed from shaft end with D1 drain port up)**
A Right hand
B Left hand
- 6 Min. Displacement Angle (Variable units only)**
0 0°
7 7°
9 9°
11 11°
13 13°
15 15°
- 7 Design**

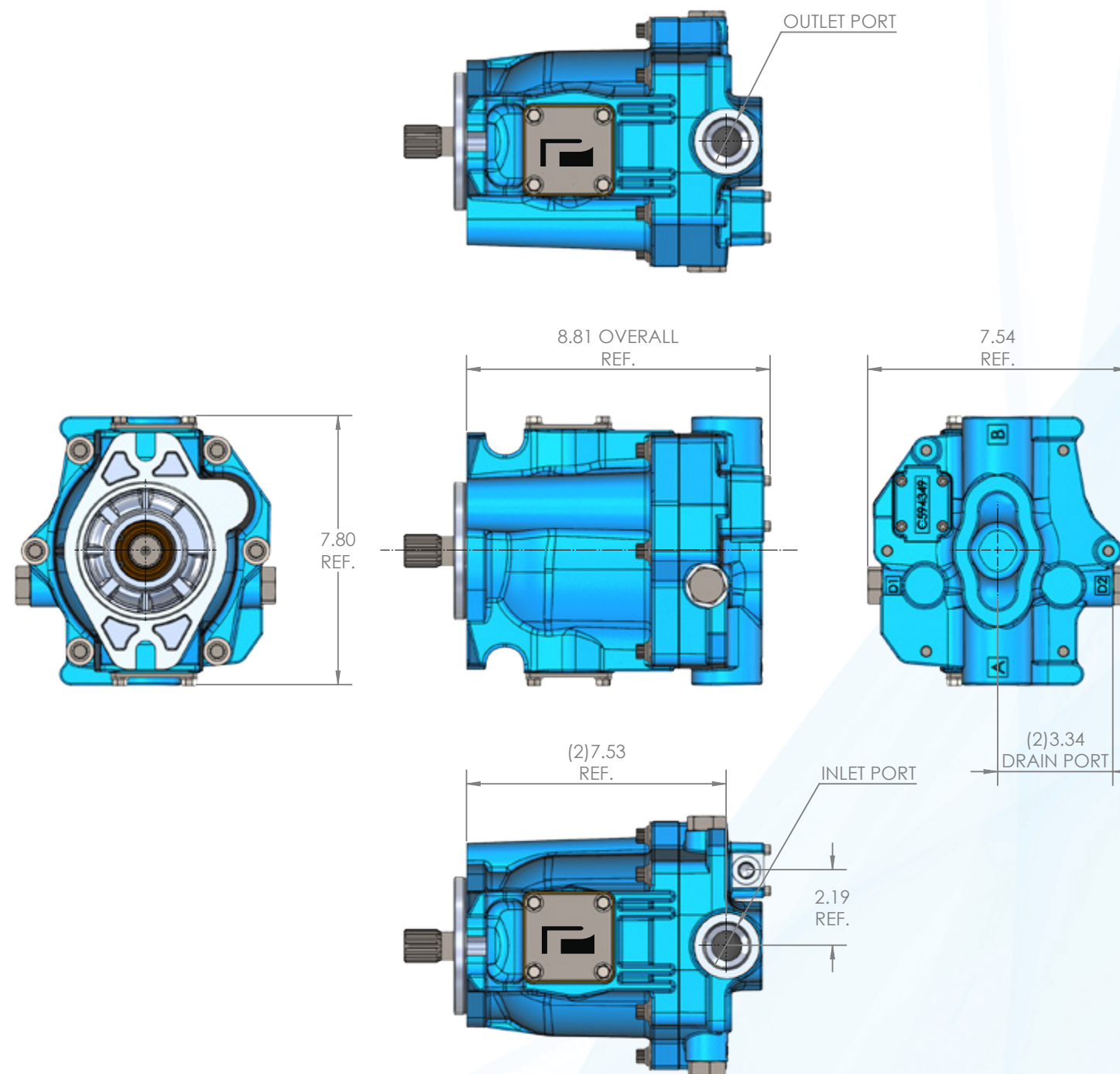



PROUDLY MANUFACTURED IN MACOMB, MICHIGAN

OEM Quality Hydraulic Pumps • OEM Quality Hydraulic Motors
OEM Quality Replacement Parts For: Vickers/Eaton, Rexroth and Caterpillar

51375 Regency Center Dr., Macomb, MI 48042 | Phone: 586-786-3920 | Fax: 586-786-7331
Email: sales@panagonsystems.com



WWW.PANAGONSYSTEMS.COM